



# 12"-16" S-SERIES SUBMERSIBLE CHOPPER PUMPS

## Materials of Construction:

**Impeller/Upper Cutter/Cutter Bar/Cutter Nut:** ..... Cast alloy steel, heat treated to minimum Rockwell C 60.  
**Casing/Bearing Housing/Guide Bracket/Elbow:** ..... Ductile cast iron.  
**Mechanical Seal:** ..... Cartridge type with silicon carbide (or tungsten carbide) seal faces and stainless steel sleeve.  
**Thrust Bearings:**..... Back-to-back angular contact ball type or face-to-face tapered roller type.  
**Flange:** ..... ANSI Class 125  
**Paint:** ..... Epoxy

DRAWINGS AND DIMENSIONS SUBJECT TO CHANGE WITHOUT NOTICE. DO NOT USE FOR CONSTRUCTION PURPOSES. CONTACT VAUGHAN FOR CERTIFIED CONSTRUCTION PRINTS.

DIMENSIONS IN INCHES

MODEL	A	B	C	D	E	F	G	H	K
S12W	37-5/8	21-7/8	65	62-7/8	6-1/8	12	10-3/4	42	7-1/4
S16W	44-3/4	25	87-7/8	74-1/2	14-3/8	20	17-1/4	49	6

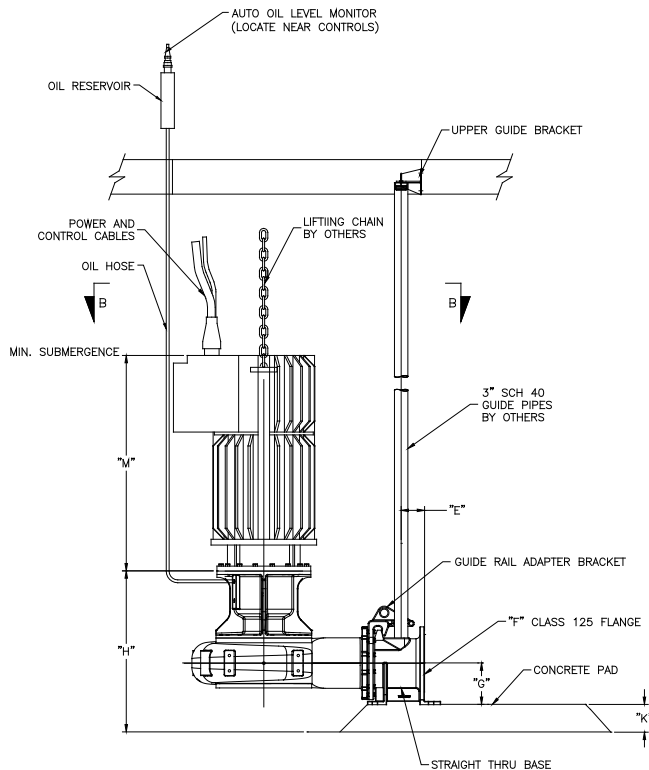

15 MINUTE IN AIR FRAME SIZES ONLY

HP	SPEED	FRAME SIZE	M
75	870	360TY	32-3/8
100	870		
125	870		
150	870	445TY	52-1/2
200	870		
250	870	449TY	61

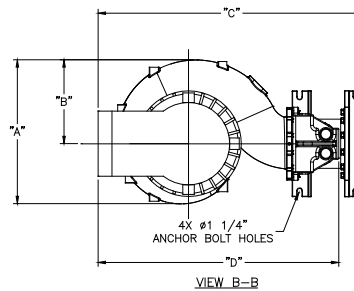

**VAUGHAN CO., INC.**  
 364 Monte Elma Road, Montesano, WA 98563  
 Phone: 1-360-249-4042 / Fax: 1-360-249-6155  
 Toll Free Phone (US only): 1-888-249-CHOP (2467)  
 Web Site: [www.chopperpumps.com](http://www.chopperpumps.com)  
 Company E-mail: [info@chopperpumps.com](mailto:info@chopperpumps.com)

**MADE IN THE  
USA**

For all current patents, see <http://www.chopperpumps.com/patents.htm>

## SPECIFICATIONS: S-SERIES 12" – 16" SUBMERSIBLE CHOPPER PUMPS

The submersible chopper pump shall be specifically designed to pump waste solids at heavy consistencies without plugging or dewatering of the solids. Materials shall be chopped/macerated and conditioned by the pump as an integral part of the pumping action. The pump must have demonstrated the ability to chop through and pump high concentrations of solids such as plastics, heavy rags, grease and hair balls, wood, paper products and stringy materials without plugging, both in tests and field applications. Pump shall be manufactured by Vaughan Co., Inc.

### DETAILS OF CONSTRUCTION

- A. Casing, Back Plate and Wear Plate:** The pump casing shall be of volute design, spiraling outward to the Class 125 flanged centerline discharge. Casing and back plate shall be ductile cast iron with all water passages to be smooth, and free of blowholes and imperfections for good flow characteristics. Backplate will include a replaceable Rockwell C 60 alloy steel wear plate with back cutter set for 0.030-0.050" clearance to cut against the rotating impeller pumpout vanes for removing fiber and debris.
- B. Impeller:** Shall be semi-open type with pump out vanes to reduce seal area pressure. Chopping/maceration of materials shall be accomplished by the action of the cupped and sharpened leading edges of the impeller blades moving across the cutter bar at the intake openings, with a set clearance between the impeller and cutter bar of 0.015-0.025". Impeller shall be cast alloy steel heat treated to minimum Rockwell C 60 and dynamically balanced. The impeller shall be keyed to the shaft and shall have no axial adjustments and no set screws.
- C. Cutter Bar Plate:** Shall be recessed into the pump casing and shall contain at least 2 shear bars extending diametrically across the intake opening to within 0.040" – 0.060" of the rotating external cutter tooth for the purpose of preventing intake opening blockage and wrapping of debris at the shaft area. Chopper pumps utilizing individually mounted shear bars shall not be acceptable. Cutter bar shall be alloy steel heat-treated to minimum Rockwell C 60.
- D. Upper Cutter:** Shall be threaded into the wear plate behind the impeller, designed to cut against the pump-out vanes and the impeller hub, reducing and removing stringy materials from the mechanical seal area. Upper cutter shall be cast alloy steel heat treated to minimum Rockwell C 60. The upper cutter teeth are positioned as closely as possible to the center of shaft rotation to minimize cutting torque and nuisance motor tripping. The ratio of upper cutter cutting diameter to shaft diameter in the upper cutter area of the pump shall be 3.6 or less.
- E. External Cutter:** The external cutter shall be used to eliminate binding or build-up of stringy materials at the pump inlet. The external cutter shall consist of opposing cutter wings which shear against the outside surface of the shear bars and the anvil, an integral cast tooth which shears against the adjacent surface of the shear bars, and a hex head sufficiently sized for ease of removal. The external cutter shall be cast alloy steel and heat treated to a minimum Rockwell C 60.
- F. Pump Shafting:** Shafting shall be heat treated alloy steel.
- G. Bearing Housing:** Shall be ductile cast iron, and machined with piloted bearing fits for concentricity of all components. Piloted motor mount shall firmly align motor on top of bearing housing.
- H. Thrust Bearings:** Shaft thrust in both directions shall be taken up by two back-to-back mounted single-row angular contact ball bearings or a matched set of face to face tapered roller bearings with a minimum L-10 life rated 100,000 hours. A pump mechanical seal shall be provided to isolate the bearings from the pumped media. The pump seal, as well as the thrust bearings shall be oil bath lubricated in the bearing housing by ISO Grade 46 oil.
- I. Pump Mechanical Seal:** The mechanical seal shall be located immediately behind the impeller hub to maximize the flushing available from the impeller pumpout vanes. The seal shall be a screw in, cartridge-type mechanical seal with Viton O-rings and silicon carbide (or tungsten carbide) faces. This cartridge seal shall be pre-assembled and pre-tested so that no seal settings or adjustments are required from the installer. Any springs used to push the seal faces together must be shielded from the fluid to be pumped. The cartridge shall also include a 17-4PH, heat-treated seal sleeve and a ductile cast iron seal gland.
- J. Automatic Oil Level Monitor:** An oil level switch shall be mounted at the top of the wet well, with a hose feeding down to the side of the bearing housing to monitor oil level and shut off the motor in event of low oil level. A relay shall be included for mounting in the motor control panel.
- K. Shaft Coupling:** The submersible motor shall be close coupled directly to the pump shaft using a solid sleeve coupling, which is keyed to both the pump and motor shafts.
- L. Stainless Steel Nameplate:** The stainless steel nameplate giving the manufacturer's model and serial number, rated capacity, head, speed and all pertinent data shall be mounted to a larger stainless steel plaque. Warning tags and oil reservoir will be mounted to this same plaque. Plaque is to be fastened to wall or structure adjacent to pump.
- M. Submersible Motor:** The submersible motor shall be U/L or FM listed and suitable for Class I, Group C & D, Division I hazardous locations, rated at \_\_\_ HP, \_\_\_ RPM, \_\_\_ Volts, 50 or 60 Hertz and 3 phase, 1.15 service factor (1.0 for Continuous In-Air) with Class F insulation. Motor shall have tandem mechanical seals in oil bath and dual moisture sensing probes. Moisture probes must be connected to indicate water intrusion. The lower motor seal shall be exposed only to the lubricant in the pump bearing housing, with no exposure to the pumped media. Motor shall include two normally closed automatic resetting thermostats connected in series and embedded in adjoining phases. The thermostats must be connected per local, state, and/or the National Electric Code to maintain hazardous location rating and to disable motor starter if overheating occurs. Motor frame shall be cast iron, and all external hardware and shaft shall be stainless steel. Motor shall be sized for non-overloading conditions.
- N. Guide Rail System:** Provide a guide rail system consisting of two galvanized or stainless steel guide rails (by others), cast ductile iron pump guide bracket, a cast ductile iron discharge base spool with mounting feet and Class 125 flanges, a 316 SS upper guide rail mounting bracket and 316 SS intermediate guide rail stiffener bracket every 10 feet.
- O. Optional Spark Proof Guide Rail System:** Provide a non-sparking guide rail system consisting of two galvanized or stainless steel guide rails (by others), cast bronze pump guide bracket, cast ductile iron discharge base spool with mounting feet and Class 125 flanges, 316 SS upper guide rail mounting bracket, and 316 SS intermediate guide rail stiffener bracket every 10 feet. System design shall prevent spark ignition of explosive gases during pump installation and removal.
- P. Surface Preparation:** Solvent wash and a single coat of Themec 431 epoxy (except motor).
- Q. OPTIONAL Premium Surface Preparation:** Solvent wash, sandblast, and coat with minimum 30 MDFT Themec Perma-Shield PL Series 431 epoxy (except motor).