

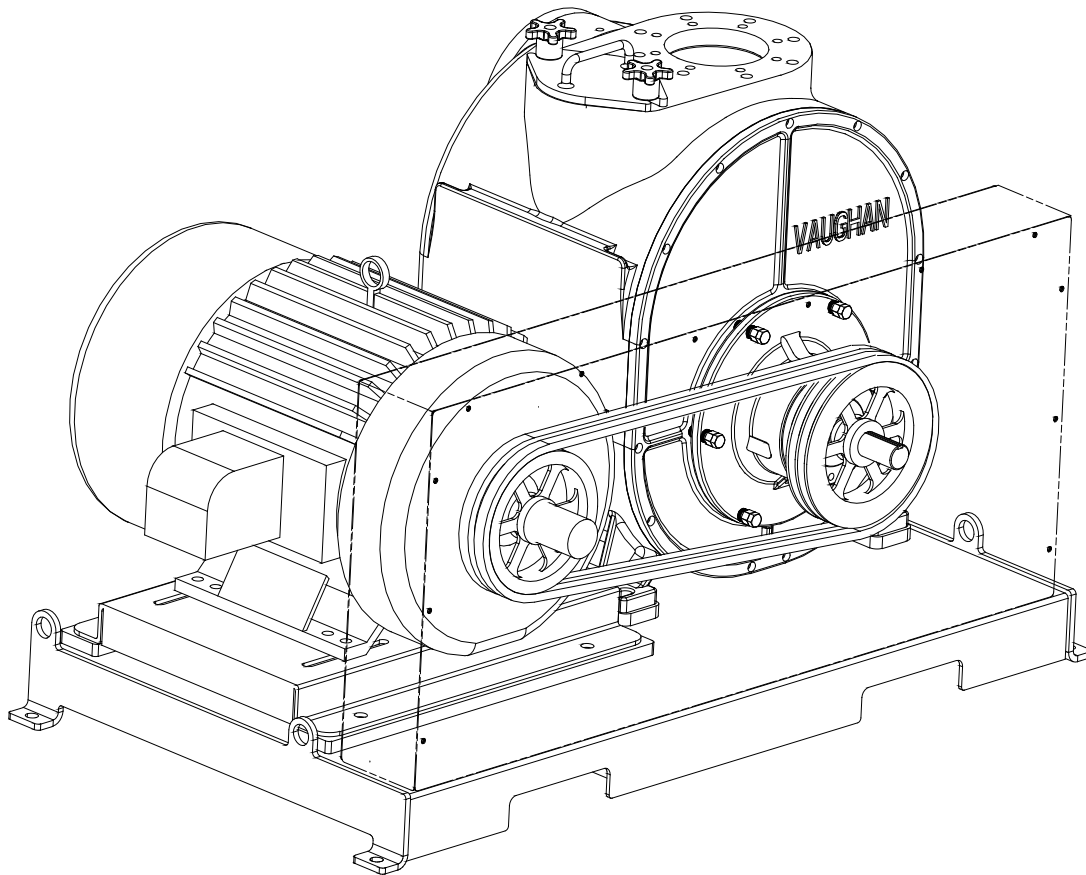

SELF-PRIMING CHOPPER PUMPS

INSTALLATION, OPERATION, AND MAINTENANCE INSTRUCTIONS



VAUGHAN CO., INC.

364 Monte Elma Road, Montesano, WA 98563
Phone: 1-360-249-4042 / Fax: 1-360-249-6155
Toll Free Phone (US only): 1-888-249-CHOP (2467)
Web Site: www.chopperpumps.com
Company E-mail: info@chopperpumps.com



INSTALLATION, OPERATION, & MAINTENANCE INSTRUCTIONS
4" & 6" SELF PRIMING CHOPPER PUMPS
TABLE OF CONTENTS

1. IMPORTANT SAFETY INFORMATION Page 1

2. DESCRIPTION OF SELF-PRIMING CHOPPER PUMP Page 3

- A. How a Vaughan Self-Priming Chopper Pump Works
- B. Pump Components
- C. Proper Applications for Vaughan Chopper Pumps
- D. Uses of Vaughan Chopper Pumps that May Cause Trouble
- E. Applications Suited for a Self-Priming Pump
- F. Expected Benefits of Chopper Pumps

3. INSTALLATION INSTRUCTIONS Page 6

- A. Receipt Inspection
- B. Storage Considerations
- C. Pump Mounting
- D. Piping
- E. Motor and Controls
- F. Bearing System
- G. Seal Oil System

4. STARTUP INSTRUCTIONS Page 11

5. NORMAL OPERATION OF PUMP Page 16

- A. Noise
- B. Vibration
- C. Seal Oil System
- D. Pressure Relief Valve
- E. Bypass Lines
- F. Cold Weather Preservation

6. SHUTDOWN OF PUMP Page 17

- A. Manual Shutdown
- B. Automatic Shutdown
- C. Emergency Shutdown

7. MAINTENANCE Page 18

- A. Routine Maintenance
- B. Corrective Maintenance

8. TROUBLESHOOTING Page 20

9. WARRANTY Page 22

SECTION 1: IMPORTANT SAFETY INFORMATION

IMPORTANT INFORMATION FOR INSTALLERS OF THIS EQUIPMENT!

This equipment is intended for installation by technically qualified personnel. Failure to install it in compliance with national and local electrical codes, building codes and within Vaughan Co. recommendations may result in electrical shock, personal injury or death, fire hazard, unsatisfactory performance, and equipment failure. If further assistance is required contact your local representative or Vaughan Co. *Keep this manual in a safe location for future reference.*

⚠ DANGER

Indicates a hazard, which, if not avoided, will result in death or serious injury.

⚠ WARNING

Indicates a hazard, which, if not avoided, could result in death or serious injury.

⚠ CAUTION

Indicates a hazard, which, if not avoided, may result in minor or moderate injury or damage to the equipment.

NOTICE

Indicates special operation or maintenance information.

- Isolate the pump hydraulically and electrically before servicing or inspecting pump. Lock out both power source and isolation valves.
- This pump may handle dangerous or contaminated fluids. There are sharp corners, edges and pinch areas which can cause serious injury. Be careful; wear protective gloves whenever possible. If you cut yourself, seek medical help immediately to avoid serious infection.
- This pump may start automatically if wired to float switches or other equipment. Before inspecting or making adjustments disconnect electrical power and lock out circuit breakers to pump motor and associated equipment. Duplex pumps with alternating relays must both be locked out; otherwise the pump you are working on may not be isolated and could start as “the alternate”. Visually confirm that the pump has come to a complete stop before proceeding.
- Motors may be equipped with built-in thermal overloads to shut off the motors in the event the temperature gets too high (as a result of low voltage, poor ventilation, overloaded lines, etc.) These motors can restart automatically as the motor cools down. DO NOT work on the pump or motor without first disconnecting and locking out the power supply.
- Enter tanks or pits with extreme caution and only after an instrument check of the pit/tank has been completed to verify the absence of dangerous gases and the presence of safe levels of oxygen. Never enter a tank or pit without a safety harness and lifeline, and an air pack. Never enter the pit without rescue personnel standing by. Follow all national and local requirements for confined space entry.
- Keep all pit openings covered when not in use. In addition to the injuries from falling, pits may contain poisonous gases or liquids.
- The pump is to always be lifted using adequate crane and sling capacity. All applicable safe hoisting practices should be employed. When doing so, rig the load to prevent flipping. Do not use the motor lifting eyes to lift the assembled pump. Use the motor lifting eyes to lift the detached motor only. Cast-in lifting eyes are designed for lifting individual pump components or sub-assemblies, not the entire pump. Only base-mounted lifting eyes may be used to lift a pump and drive assembly.
- Do not allow people under the pump assembly while it is being lifted.
- Pump components can be heavy. Proper methods of lifting must be employed to avoid physical injury and/or equipment damage. Steel toed shoes should be worn at all times.
- Never operate a pump with closed or blocked discharge valves. This will destroy the pump and could be dangerous to personnel.

- Do not allow liquid to be trapped in pump or piping between two closed valves. Always drain or vent the piping/pump between two closed valves. Failure to vent or drain could allow dangerous pressures to build causing rupture damage that may result in injury, death, and equipment damage.
- Safety apparel to be worn when working on or making adjustments to pumps should include:
 - Heavy work gloves when handling parts with sharp edges, especially impellers.
 - Safety glasses (with side shields) for eye protection
 - Steel-toed shoes for foot protection when handling parts, heavy tools, etc.
 - Other personal protective equipment to protect against hazardous/toxic fluids and gases.
- Do not operate this equipment unless safety guards or devices are in place and properly adjusted.
- Let the pump cool to ambient temperature before beginning work on it. A warm pump can contain compartments of pressurized fluid, which may vent violently during disassembly.
- Never apply heat to remove parts unless specifically directed to do so in overhaul instructions. Use of heat may cause an explosion due to trapped fluid, resulting in severe physical injury and property damage.
- Pressure may build up in the standard mechanical seals used in Vaughan pumps. Whenever checking or maintaining the oil in the Vaughan Cartridge Seal, or the welded metal bellows seal with seal oil chamber, make sure the pump and seal are cool to the touch. Use care when removing the oil chamber plugs and pressure relief valve, in case any residual pressure exists. If pressure exists, the plug could become a projectile and/or contaminated oil could spray.
- As it is possible to run Vaughan Chopper and Screw pumps dry, for quality assurance or troubleshooting reasons, it is extremely important to ensure suction and discharge connections are always properly guarded to prevent anything (i.e. foreign objects or pump parts) from being thrown from the pump as a projectile. All pumps must be run with suction and discharge piping in place, or blind flanges installed on suction and discharge connections. Blind flanges should be vented to avoid pressure build-up. Note that cast rotating parts could break if metal to metal contact occurs while the pump is running dry.
- Shut pump off when adjusting fittings to avoid being sprayed with pumpage. Pumped materials may be hot, corrosive, poisonous, infectious, or otherwise dangerous to personnel.
- Pump motors are connected to high voltage. Allow only qualified electricians to service this electrical equipment only in accordance with the latest revision of the National Electrical Code and other applicable requirements.
- Make certain all personnel are clear of equipment before operating.
- This equipment may not meet explosion proof requirements for hazardous environments unless specifically ordered for this purpose. Introducing non-explosion proof equipment into a hazardous environment as defined by the National Electrical Code can cause a dangerous explosion.
- This pump uses oil which, if spilled, can cause a slipping hazard and danger to personnel.
- Keep hands, feet and clothing away from moving machinery.
- Never clean, oil, adjust, or repair machinery while in motion.
- Keep electrical control panel area clear to avoid to avoid hazard to personnel. If a person should trip and fall into an open panel enclosure, serious electrical burns can result.
- Keep electrical control panel doors closed except to make adjustments or repairs by a qualified electrician.
- Overheated pumps can cause severe burns and injury. If overheating of pump casing occurs:
 - Shut down pump immediately.
 - Wait for pump to cool to air temperature.
 - Slowly and cautiously vent pump at drain plug.
 - Trouble shoot cause of overheating.

If there are any questions regarding the safe and proper methods for operating or servicing this pump, please contact Vaughan Company for assistance.

SECTION 2: DESCRIPTION OF VAUGHAN SELF-PRIMING CHOPPER PUMP

A. HOW A VAUGHAN SELF-PRIMING CHOPPER PUMP WORKS

The Vaughan self-priming chopper pump is specifically designed for pumping debris-laden materials in a liquid slurry. Material is chopped up by the pump impeller as it enters the pump at the suction plate, or Cutter Bar, so that particle size is reduced and downstream plugging problems are greatly reduced. The pump impeller serves a dual function of both pumping and chopping.

A pump is considered to be “**primed**” when all of its waterways (suction piping, casing, etc.) are completely filled with water and no air is present in the system.

During the priming process, residual liquid in the pump housing is recirculated through the casing, drawing air from the suction side of the housing. Air is allowed to separate from the water in the discharge side of the housing. This air is forced out of the discharge port of the pump. As air is removed from the suction line, a vacuum is created which begins to pull liquid into the suction piping and ultimately into the pump housing, which primes the pump.

Note that the air that has been expelled from the suction pipe MUST be released to the atmosphere for priming to take place. This is accomplished by the use of a bypass line connected from the pump discharge going back to the pit. Alternatively, air may be vented through an open discharge with no check valve.

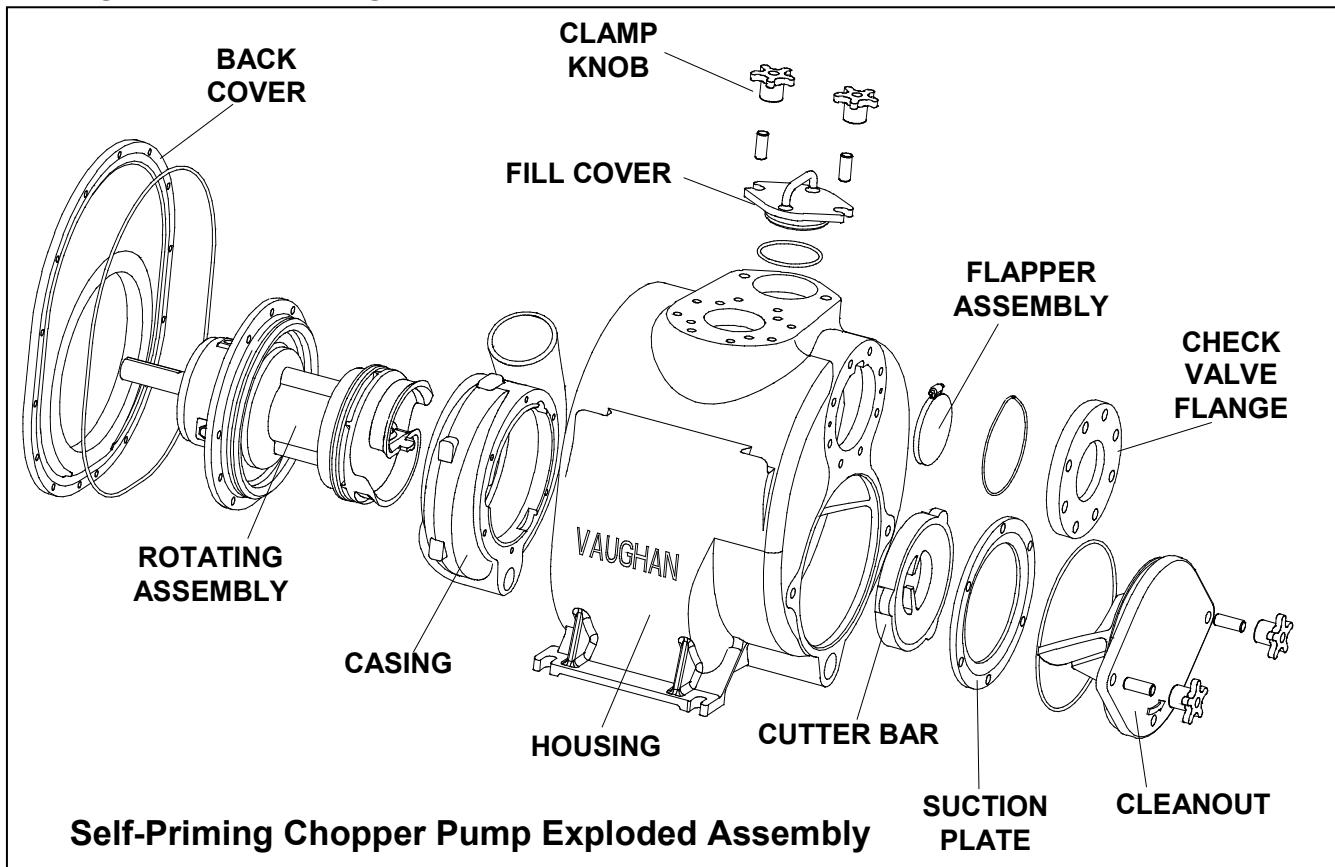

B. PUMP COMPONENTS

CHOPPER IMPELLER:

The impeller on the Vaughan pump serves two purposes. First, it induces flow by propelling liquid material into the pump casing. Second, the impeller also provides chopping capability for the pump. The leading edge of each impeller blade slopes forward to creating a knife edge so that as material enters the pump, it is caught and cut between impeller blades and the stationary bars of the cutter bar. The impeller is normally made of cast steel and is heat treated to Rockwell C60.

CUTTER BAR:

The cutter bar serves two functions. First, it acts as a “wear plate” to serve as a pressure seal at the entrance of the pump. The pressure generated by the impeller is kept inside the pump by the close clearances of the cutter bar plate. Second, the cutter bar includes two shear bars that partially block the entrance to the pump so that material is chopped by the pump impeller cutting against these stationary shear bars. The cutter bar is made of cast steel and is heat treated to Rockwell C60.

UPPER CUTTER

The upper cutter is located behind the impeller and cuts against the pumpout vanes and the impeller hub to for the purpose of preventing stringy materials from wrapping in the mechanical seal area. The upper cutter is made of alloy steel heat treated to Rockwell C60.

CUTTER NOSE

The cutter nose design prevents pump binding by cutting stringy materials that could otherwise wrap around the shaft and block the intake opening. The cutter nose is made of cast alloy steel heat treated to Rockwell C60.

MECHANICAL SEAL:

All Vaughan self-priming chopper pumps use a high-quality mechanical seal to isolate and protect the oil-bath ball bearing system from contamination from the pumpage. The seal is located immediately next to the impeller on the shaft. Mechanical seal faces are made of silicon carbide or tungsten carbide for long life in abrasives.

An independent seal oil reservoir located in the bearing housing (refer to cross-sectional view of rotating assembly) allows for proper lubrication of the seal and cooling of the seal faces. The oil can be easily changed by removing the drain plug at the bottom of the bearing housing. Replace with ISO grade 46 turbine oil, hydraulic oil, or automatic transmission fluid through the top fill/vent. If leakage into the seal oil reservoir is severe, so that material is flowing out the vent onto your floor, then the mechanical seal probably needs to be replaced.

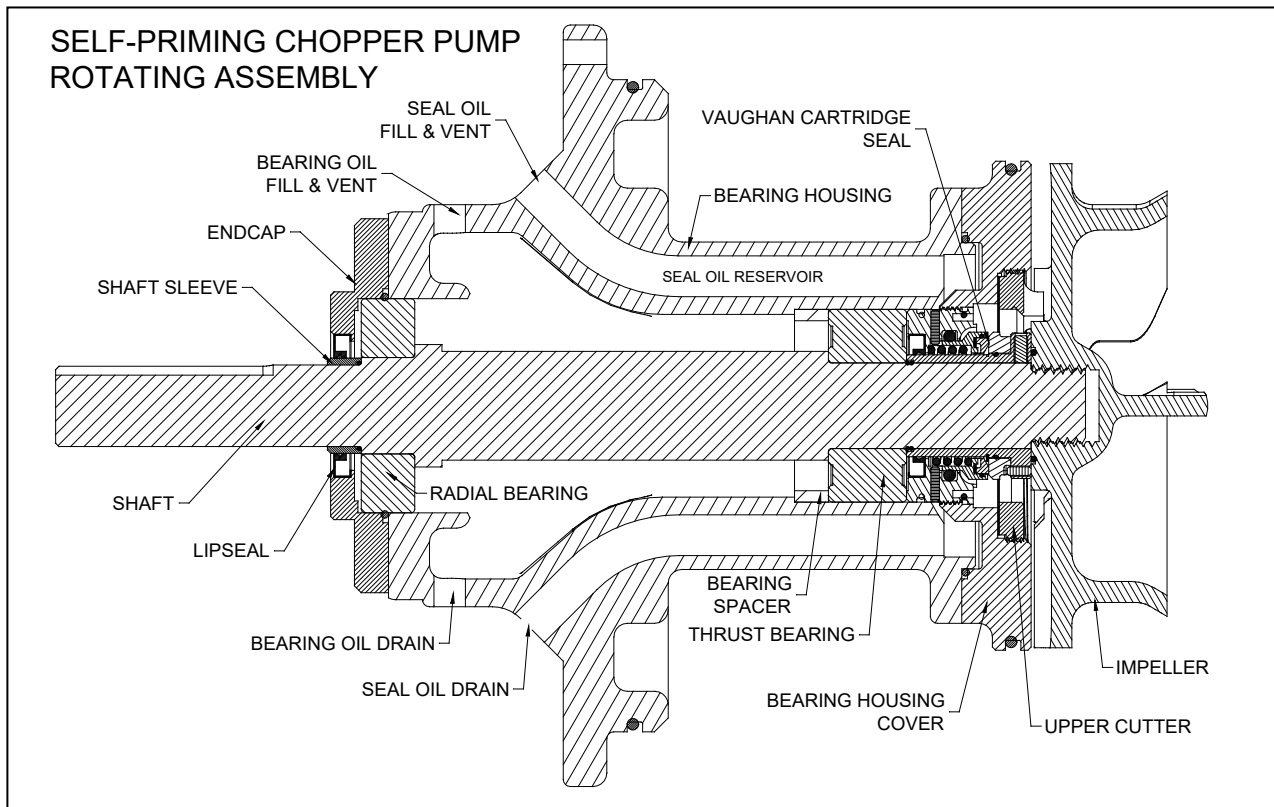

MOTOR MOUNTING:

Vaughan Self-Priming chopper pumps can be directly driven by a C-Face electric motor through a TB Woods Sure-Flex elastomeric coupling. The motor is rigidly mounted to the pump bearing housing by a machined and piloted motor stool. This piloted mounting ensures proper motor and pump shaft alignment without requiring special alignment of the motor and pump shafts at your plant. If your pump is belt-driven, it will either have the motor mounted to the side of the pump or overhead, depending on how it was ordered. Belt driven pumps have arrangements for motor movement to adjust the belt tension. It is advisable to use flexible conduit to the motor so that the motor can move with the rotating assembly for adjustment or service to the wetted parts of the pump.

C. PROPER APPLICATIONS FOR VAUGHAN CHOPPER PUMPS

Vaughan Chopper Pumps are used for pumping liquid slurries contaminated with debris which can be chopped and mixed into the slurry. The benefit of this approach is that a more homogenous slurry is pumped, making some slurries pumpable (which might otherwise not be pumpable) and eliminating downstream plugging in other equipment. Also, screens located upstream of the pump may often be eliminated, cutting labor costs. Vaughan pumps are routinely used to pump the following slurries:

Sewage and sewage sludge	Wood chips and paper waste.
Fish waste.	Animal manures (dairy cow, pigs, and chicken).
Vegetable waste.	Animal fat in rendering and hide processing plants.
Mill scale.	Feathers mixed with blood and water in poultry plants.
Plastic debris.	Aluminum chips from machining operations.
Coal slurry.	Lead oxide and plastics in battery plants.
Oil sludges in oil refineries.	

System design is very important in making any pump work successfully in pumping debris-laden slurries. There must be enough liquid so that material can be pumped. Also, liquid and material must be able to flow freely to the pump.

D. USES OF VAUGHAN CHOPPER PUMPS THAT MAY CAUSE TROUBLE

If the system is not designed correctly for proper handling of your material, or if the pump is incorrectly chosen for your system, the pump may not work to your satisfaction or the pump may experience early failures of seals or bearings. The following problems can be experienced:

1. When pumps vibrate, they are damaged.
2. A pump must be operated in the solid line areas of its pump performance curve. Operation in the dashed lines indicates vibration areas.
3. Operating a pump against very low backpressure damages pumps.
4. Operating a pump against too much backpressure damages pumps.
5. Chopper pump impellers with the largest number of blades are the most efficient, but they also provide the poorest solids handling. Added impeller blades block the inlet and cause increased binding on fiber during chopping. When pumping sewage and similar slurries, choose impellers with the *least* number of blades.
6. When pumping materials that float or settle in a pit, agitation and chopping with the pump are required before pit pumpout.
7. You cannot pump slurry that is too hot from an open pit. 60° C (140° F) is a reasonable upper limit for a self-priming pump due to NPSH requirements.
8. You must have a reliable electrical power supply for a pump to work properly. If you have too much voltage drop because of an undersized cable or transformer, the motor will not be able to provide full power to the pump and it will stall during chopping of debris. You must ensure that the overloads are properly sized. If a VFD is used, it must be properly sized and configured.

E. APPLICATIONS SUITED FOR A SELF-PRIMING PUMP

There are several reasons why a self-priming pump may be the appropriate choice for a particular application, including:

1. A self-priming pump can be installed in locations where there is not sufficient overhead room to lift or install a submersible or vertical wet well pump.
2. A self-priming pump is easily belt driven, providing more flexibility in pump performance.
3. Neither the pump nor the motor need to be submerged, allowing greater access to pump components and ease in maintenance.
4. Plant personnel do not need to be exposed to the hazards of entering a pit or wet well.

APPLICATIONS THAT ARE **NOT** SUITED FOR A SELF-PRIMING PUMP include:

1. Pumping large items that will not easily enter the suction pipe.
2. Pumping large amount of floating debris.
3. Pumping hot fluids (above 140° F).
4. Pumping from a very deep pit (**20 feet or greater**). Remember that your maximum suction lift is limited by atmospheric pressure and/or the pressure available in the suction pit. At sea level, you have a maximum 34 feet of head available, not counting further losses due to suction lift and friction. Even with a complete vacuum inside the suction side, if more than 34 feet of head is lost in transporting the fluid to the pump, the pump will never prime. This is a limitation of nature and cannot be changed. When you consider vapor pressure and NPSH required, you can quickly see why **maximum lifts of 20 to 25 feet are recommended**. (Please consult Vaughan engineering if > 20 feet.)
5. Pumping very viscous fluids.
6. Pumping any volatile fluid.

F. EXPECTED BENEFITS OF CHOPPER PUMPS

Most customers who install a Vaughan pump see several advantages:

1. Minimal pump attention required.
2. Minimal chances of pump plugging.
3. Minimization of downstream plugging problems because material is preconditioned.
4. Elimination of ancillary grinders or comminutors.
5. Long and reliable life of the Vaughan pump.

SECTION 3: INSTALLATION INSTRUCTIONS

A. RECEIPT INSPECTION

Prior to shipment Vaughan pumps are carefully crated and inspected to ensure arrival at your plant in good condition. On receiving your pump, examine it carefully to assure that no damaged or broken parts have resulted from mishandling during shipping. Turn the pump shaft by hand and verify that it turns over smoothly. If the shaft binds, look for debris between impeller and cutter bar. Otherwise, shaft binding could indicate damage. If damage has occurred, report to your carrier immediately, and consult your local Vaughan representative.

B. STORAGE CONSIDERATIONS

If equipment is to be stored for longer than two weeks, take the following action:

1. Coat exposed steel with a light layer of grease to protect the equipment from corrosion. The interior of the pump can be accessed by removing the suction cover; a spray lubricant can then be applied to the cutting parts of the pump.
2. Rotate the motor 1-1/4 turn once each week to keep the bearings from sitting in one position for extended periods of time.
3. Avoid storing rotating equipment near other vibrating equipment. The vibrations can cause damage to the ball bearings and cause premature failure once the equipment is started up.
4. Store rotating equipment in a clean, dry, heated area away from areas where it could be damaged from impact, smoke, dirt, vibration, corrosive fumes or liquids, or from condensation inside the motor or pump. It is helpful to cover equipment with plastic.

C. PUMP MOUNTING

Vaughan pumps are heavy and will require a crane to lift into position. Lifting the pump by the lifting lugs at the base is always a safe method for lifting. Do not lift by the motor eye.

When mounting and positioning the pump, allow at least 18" for access to the cleanout in order to access the interior of the housing.

WARNING

The pump is to always be lifted using adequate crane and sling capacity. All applicable safe hoisting practices should be employed. When doing so, rig the load to prevent flipping. Do not use the motor lifting eye to lift the assembled pump. Use the motor lifting eye to lift the detached motor only. Cast-in lifting eyes are designed for lifting individual pump components or sub-assemblies, not the entire pump. Only base-mounted lifting eyes may be used to lift a pump and drive assembly. Do not allow people under Vaughan equipment during hoisting operations. Consult the Vaughan Co. shipping department for weight of your equipment if you are in doubt.

ANCHORS

Vaughan pumps should be securely bolted to a level, flat floor or slab with stainless steel anchors to minimize operational vibrations. Expansion-type, cast-in place J-bolts, bolts mounted in sleeves, and epoxy anchoring systems are all acceptable anchoring means.

LEVELING THE BASE

Vaughan Co. assembles and aligns the completed pump and motor assembly on a level surface at the factory and runs the pump at speed to measure dry-run vibration levels and to ensure that no metal-to-metal contact occurs. If the base is not mounted to a level, flat surface in your installation, twisting of the base and pump could occur that can cause metal-to-metal hitting of the cutting parts during operation. Careful shimming is required to properly align the suction piping to the pump and to ensure that the pump base is level (not twisted) and properly aligned to the suction piping. As the pump is shimmed, turn the pump shaft over by hand to ensure that no metal-to-metal contact is occurring. If metal-to-metal contact is discovered during pump startup and actual pumping, additional shimming may be required to take additional twist out of the base and pump. Do not completely tighten the anchors until grouting is completed and is properly hardened. Note that this pump is expected to be mounted horizontally with no more than 0.2" rise per foot (+/- 1° of level). If mounted at an angle, both sets of bearings may not receive adequate oil lubrication. If this cannot be accomplished consult factory for other options.

GROUTING

Vaughan Co. recommends that all horizontal pumps be grouted in place. Standard horizontal baseplates include grout holes and vents to facilitate grouting. The purpose of grouting is to prevent shifting of the baseplate, to reduce vibrations (by increasing mass), and to fill in irregularities in the foundation. A typical mixture for grout is one part Portland cement and two parts building sand combined with enough water to allow grout to flow under the base. Wet the concrete foundation before grouting the pump in place. A wooden form is needed around the pump base to retain the grout. Add grout until the entire underside of the pump base is filled, working air out with a stiff wire or rod through the grout holes. Cover the exposed grout with wet cloth or burlap to prevent cracking during setup. Remove the wooden forms once the grout is setup and then smoothly finish the exposed surfaces. Fully tighten the anchors only after the grout is completely hardened. Shims used for leveling and alignment may be left in place.

DIRECT-DRIVE MOTOR ADJUSTERS

Horizontal direct-drive pumps use a machined motor stool aligned to the motor C-Face end bell so that pump/motor coupling alignment is assured. Threaded adjustable motor supports are provided under each of the motor feet that are designed to just touch the pump base when aligned at the factory. The adjusters are held in place by a set-screw. After shimming and grouting the base, loosen each motor adjuster setscrew and reset the adjusters to that they just touch the base, then re-tighten the setscrew.

BELT-DRIVE ADJUSTMENTS

Belt-drive pumps have been aligned and tensioned at the factory, **but the belts are loosened before shipping**. You will need to properly re-adjust the belt tension and alignment following the instructions in Section 4 of this manual. Belts that are too tight can cause premature belt or bearing failures, belts that are too loose may experience belt slipping and belt failure.

D. PIPING

Be sure that the weight of piping connected to the pump suction and discharge flanges is properly and independently supported. Do not expect the pump to support your piping system, as this will cause serious stresses on the pump. These stresses can result in a broken or cracked casing, excessive vibration, and premature bearing and seal failures. Before bolting piping to the pump, make sure that flanges are closely aligned.

NOTICE

Never use force to draw piping to pump flange. Excess forces on the pump will reduce seal and bearing life. Be sure all piping connections are tight and properly supported before operation.

As a general rule in piping layout, avoid frictional losses by minimizing fittings and abrupt changes in direction and by choosing piping size carefully. Use long radius elbows when possible. Remember when pumping sludge that this material has significantly higher friction losses than water, so larger diameter piping is always helpful.

DISCHARGE PIPING

If you are going uphill or going into a force main, or if there is more than one pump pumping into a common header, a check valve and isolation valve will be required on the discharge of the pump. Note that the pumps have pressure taps at the tops of suction and discharge flanges. These fittings are needed at pump startup and during any troubleshooting.

CAUTION

Never operate a pump with closed or blocked discharge valves. This will overheat the pump and create a hazard to personnel.

SUCTION LINE PIPING

The layout of suction piping should be carefully considered on self-priming pumps to avoid restricting flow to the pump. The goals of an "ideal" suction piping system should consider the following:

Minimize Volume of Suction Piping

Initial priming time will depend upon the total volume of air that will initially be needed to be removed from the system.

- ✓ Keep piping as short and as direct as possible.
- ✓ Although a smaller diameter of suction piping will decrease the volume of air present that will need to be expelled before the pump can prime, it will also lead to greater frictional losses and could present an NPSH problem.

Minimize Air Entrapment & Turbulence

- ✓ Suction lines should not flow downhill at any point during travel to pump.
- ✓ Check lines to ensure that there are no leaks or plugs.
- ✓ Suction lines should not be too close to pit wall. Recommended distance is 1 ½ times the pipe diameter.
- ✓ Suction lines should not be too close to any inflow or this could lead to excessive air entrapment in the pumped fluid. Install a baffle if necessary to prevent turbulent flow from interfering with incoming flow to the pump.

MINIMIZE FRICTION

- ✓ Never install a throttling valve or a check valve in a suction line.
- ✓ Avoid bends and fittings and keep pump as close as possible to the tank from which you are taking suction.
- ✓ Keep the pipe size at least as large as the inlet flange.
- ✓ Add suction bell to inlet of piping to reduce entrance friction losses.

Long and restrictive runs of suction piping can contribute to gas binding problems or loss of prime, especially in scum and sludge transfer applications. Typically, suction piping the same size as the suction inlet is recommended, with a suction bell to help reduce entrance losses and turbulence.

MINIMUM INLET SUBMERGENCE REQUIREMENTS

Greater pipe submergence is required for higher GPM in order to prevent vortex formation and air entrapment in the pumped liquid. The use of a **suction bell** (inverted reducer) will help to reduce the submergence required. In general, the smaller the suction pipe, the greater the recommended submergence that is required due to the increased velocity of the flow entering the line.

When possible, try to position the inlet to the suction line as close as possible to the bottom of the pit, allowing a distance of approximately $1\frac{1}{2}$ x the pipe diameter (suction opening) between the pipe inlet and the bottom.

You can use the chart below to estimate submergence depth based on the diameter of the inlet to the suction line. Note the reduction in submergence required for larger suction inlet diameters.

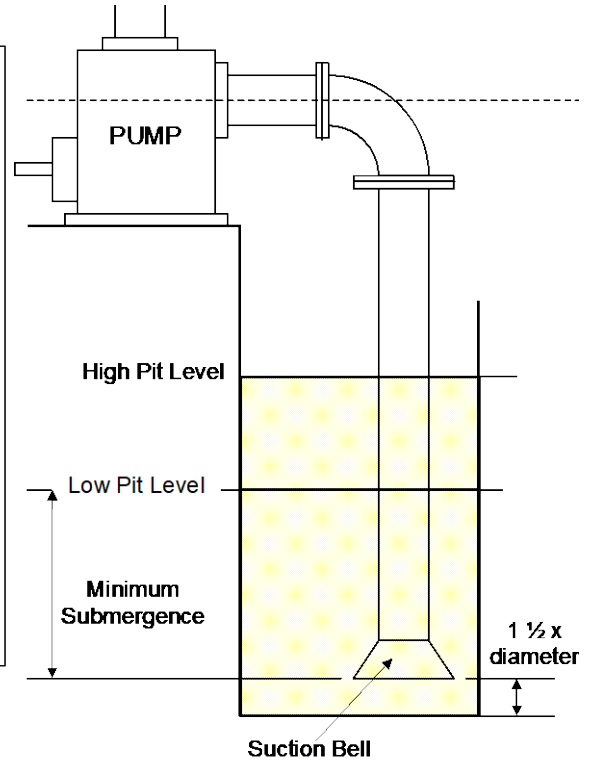
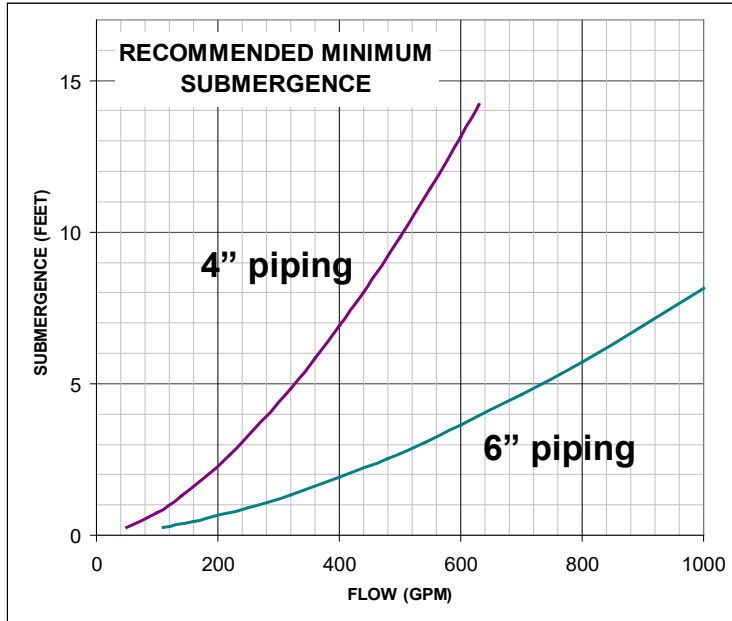

BYPASS LINES

With all pumps, air may be introduced into the system during normal operation; the volume of air is usually small enough that it does not impact the performance of the pump significantly or present any problems in opening the discharge check valve when the pump is turned on.

With a self-priming pump, the amount of air present that must be expelled is much greater. If there is too much air that cannot escape, there will not be enough pressure buildup on the discharge side of the pump to open the check valve.

Air must be able to escape from the system during priming. If there is a check valve installed on the discharge line and/or the discharge is not open to atmosphere, a bypass line or air release valve (ARV) must be used to allow air to vent to the atmosphere until the pump is primed and all air has been expelled. The bypass line or air release valve must be located between the discharge flange and discharge check valve. The diameter of the bypass must be large enough such that it does not restrict flow of the pumpage, yet also not significantly reduce the pump's discharge capacity. A bypass diameter of at least 1" should allow for adequate venting and flow of bypass fluids if an ARV is used it should be located at the high point in the system before the check valve. The system can be operated with no bypass line or ARV **only if the discharge is vented to atmosphere and no discharge check valve is used.**

If there is a check valve installed on the discharge line and/or the discharge is not open to atmosphere, a bypass line or ARV must be used to allow air to vent to the atmosphere until the pump is primed and all air has been expelled.

The diameter of the bypass must be large enough such that it does not restrict flow of the pumpage, yet also not significantly reduce the pump's discharge capacity. A bypass diameter of 1" should allow for adequate venting and flow of bypass fluids.

Since a bypass line will divert some of your pump's output flow back to the suction pit, it may be desirable to install a solenoid-operated valve which can be used to automatically shut off the bypass line after the pump has primed. A timer could be used in conjunction with the valve to open the valve each time the pump turns on and re-primed, and shuts the valve a set time after priming.

If a manual shut-off valve is used with a bypass line, it must remain open during normal operation. Liquid will continue through the bypass line during normal operation, so the bypass line should be directed back to the wet well to prevent any hazardous pumped liquids from spilling.

E. MOTORS AND CONTROLS

Most motors provided on Vaughan pumps are TEFC C-Face and are not designed for hazardous environments or rated as explosion proof. However, some applications require explosion-proof motors. If your pump is located in a hazardous location, be sure you ordered and received your pump with an explosion-proof motor and that you use an electrician experienced in hazardous environment wiring and controls.

Vaughan Chopper Pumps, because they cut and condition the material they pump, require motor protection with correctly sized breakers, starters, and overload protection. A Chopper Pump can jam and stall on material too tough to chop, such as steel rebar. Therefore, carefully chosen overload protection for your expensive motor is critical to avoid motor burnout. Note that nuisance tripping during chopping can occur if you do not have an adequately sized circuit breaker. The circuit breaker should never open during chopping, only during a short circuit. High current trip settings for Starters and VFD's should be set at 110% of motor nameplate full load current to prevent the current spikes from tripping out those devices while chopping.

Selecting a motor with a base speed at the upper end of your operating range and slowing it down to hit the low range results in lowest available torque and may not be recommended. *Note, when slowing a motor down below nameplate speed with a VFD it is very important to remember that available horsepower drops in direct proportion to speed reduction, so a 100 HP motor running at 30 Hz can only make 50 HP max at 30 Hz.*

Selecting a motor with a base speed at the lower end of your operating range and speeding it up to hit the high range results in the highest available torque and is generally preferred for chopper pump applications. *When speeding a motor up above nameplate speed, available horsepower = nameplate horsepower.*

Minimum allowable speed for Rotamix applications is 75% of base speed. Minimum allowable speed for other applications is dependent on system curve, and is the speed required to maintain minimum allowable flow per our published curves. Consult Vaughan Co. for assistance if needed.

Severe duty applications like septage receiving, screenings, beef processing, or any application with an external cutter often require oversizing the motor to get sufficient torque. Oversizing the motor has the added benefit of increasing rotational inertia to help carry the impeller through each chop. When driving chopper pump motors with a VFD, it is important that Constant Torque type VFD's be specified. Constant torque VFD's allow for maximum chopping torque at all speeds. (Variable Torque units have reduced torque and horsepower at reduced speeds)

F. BEARING SYSTEM

Self-priming pumps use oil-bath bearing lubrication. Oil level is indicated by a sight glass mounted on the side of the bearing housing.

ISO 46 hydraulic oil is added at the factory at a level just high enough to reach the bottom of the level hole located at the left side of the bearing housing (when viewed from the motor end). This level corresponds to the centerline of the lowest ball in the thrust bearing(s) as shown in the illustration on the following page.

Oil is filled through the plug at the top of the bearing housing, and can be drained at the bottom of the housing. Do not overfill the housing.

G. SEAL OIL SYSTEM

The seal oil reservoir is also located in the bearing housing but is a separate chamber. The reservoir is filled through the fill/vent plug at the top of the bearing housing (see picture at right); this chamber is filled such that oil can be seen at the top of the reservoir. The seal oil is drained through the matching drain plug located at the bottom of the bearing housing.

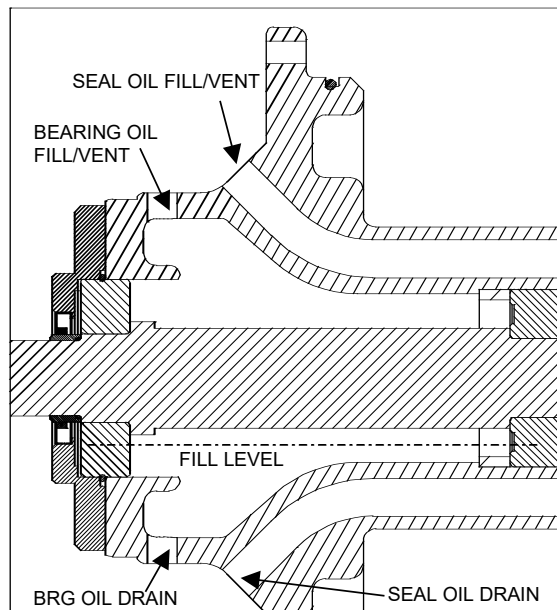

SECTION 4: PUMP STARTUP INSTRUCTIONS

NOTICE

Review safety information in Section 1 of this manual before proceeding.

- 1) All directly-driven Vaughan pumps using C-Flange electric motors are designed and built for automatic alignment of motor and pump shafts during assembly. Four motor adjusters have been supplied with your pump. Tighten them just enough to support the weight of the motor but no more.
- 2) Belt-driven pumps have shipped with the belts de-tensioned and the belts will need to be tightened before startup. Vaughan's bill of material (BOM) for your particular pump and belt-drive system lists the belt tension required by the drive manufacturer. After the pump is installed, plumbed, and bolted down into final position follow the procedure below to tighten the belts to the tension noted on the pump BOM.

WARNING

Lock out power source before tensioning belts. Install the belt guard before applying power to the pump. Never operate the pump without the belt guard installed.

- a. Remove the belt guard outer cover and set it aside. Loosen the motor hold down bolts and turn the belt tensioning bolts under motor until belts are tight and can be depressed approximately $\frac{1}{2}$ " in the center of one belt by hand.
- b. Place a steel straight edge across the two belt sheave's centers, passing directly over the center of the shafts. If the two sheaves are in alignment, the straight edge will touch each edge of each sheave. If the straight edge doesn't touch in four places, move the motor with the adjusting screws (and perhaps axially if necessary) to obtain a perfect four point match. Close is not acceptable. Even a small misalignment can cause vibration and premature belt/sheave wear. You may need to push on the back side of the motor with the adjusting screw. The screw will push if it is threaded out about $\frac{3}{4}$ ".

- c. Once the sheaves are in proper alignment, the belt tension must be set. During tensioning, move the motor carefully so you don't change the sheave alignment. To check the tension, press in the center of one belt length with a special belt tensioning tool (Vaughan #V800-860) for single belt; (Vaughan #V800-861) for banded belt. For banded belt, the total force will be lbs. per rib/strand times the number of rib/strands in the belt. It is very important to set the tension correctly. See the bill of materials for the correct tension.
 - d. The alignment/tensioning may have to be repeated until both tension and alignment are correct, as setting one changes the other. These also can change when the motor hold down bolts are tightened. Once the tension and alignment are correct with all bolts tight, reinstall the belt cover.
- 3) Perform a pump rotation check to ensure Clockwise rotation (as viewed from the motor end) before startup. At the control panel, hit the "ON" button, then the "OFF" button as fast as possible to "jog" the motor at a slow rate. If the motor turns clockwise, you are ready to start the pump. If the motor turns counterclockwise, (wrong direction), then following your plants established lockout/tagout procedures open the circuit breakers to the motor panel, and reverse any two leads on the motor starter in the control panel. Close the breakers to the panel and recheck the motor direction to be sure it's correct.

NOTICE

If the pump is allowed to run backwards for any significant length of time, the impeller can loosen, and eventually damage the pump.

4. To prime the pump add liquid through the fill cover located at the top of the pump housing until the housing is full. Be sure to replace the fill cover tightly before starting the pump.

After initial priming, when the pump is shut off, enough liquid will remain in the pump housing to allow for subsequent priming without the need to add additional liquid. However, if the pump has been out of service for an extended length of time or if any evaporation may have occurred, it may be necessary to check for proper fluid levels within the pump housing to ensure proper priming.

NOTICE

When the pump is being put into service for the first time, it is necessary to fill the housing with fluid. Otherwise, the pump will not prime and damage to the seal assembly and pump components could occur.

- 5) Review the start-up and certification checklist in this manual, open suction and discharge isolation valves, confirm pump housing is filled, and start the pump.

CAUTION

Never operate a pump with closed or blocked discharge valves. This will destroy the pump and could be dangerous to personnel.

- 6) The startup instructions are incorporated into the Startup and Certification Checklist. When the Startup and Certification Checklist is completed please send a copy of the completed checklist to: STARTUP@CHOPPERPUMPS.COM. We will verify that the pump and system are properly matched to protect your investment and our reputation.

NOTE: Because the self-priming pump must pull water uphill using vacuum generated inside the pump, there are limits as to how hot the liquid in the pit can be and what kind of suction lifts can be achieved. Be particularly careful with liquids 140° F and hotter and with suction lifts or more than 20 feet. Vaughan self-priming chopper pumps can provide lifts up to about 25 feet with cold 60° F water.

NOTICE

Pump speeds and operating conditions must fall within the acceptable limits of the performance curve of the pump. Do not operate in the dashed portions of the curve



DATE: _____

Project Name: _____ Location: _____

Pump S/N: _____ Equipment ID/Tag#: _____

Startup Performed By: _____

Customer Contact Info _____

Contractor Contact Info _____

Engineer Contact Info _____

PRE-STARTUP CHECKLIST

- Was rotating equipment stored in a clean, dry heated area away from areas where it could be damaged from impact, smoke, dirt vibration, corrosive fumes, or liquids, or from condensation inside the motor or pump?

Yes _____ No _____

- If no, are you aware of any damage the equipment may have sustained?

- Was the shaft rotated 1-1/4 turn once each week? Yes _____ No _____

- If no, how often was the shaft rotated?

- Was the exposed steel covered with a light layer of grease or Cosmoline to protect the equipment from corrosion?

Yes _____ No _____

- Was the bearing housing kept filled with ISO Grade 46 hydraulic oil (does not apply to SE Submersibles)?

N/A _____ Yes _____ No _____



DATE: _____

Project Name: _____ Location: _____

Pump S/N: _____ Equipment ID/Tag#: _____

Startup Performed By: _____

Customer Contact Info _____

Contractor Contact Info _____

Engineer Contact Info _____

**VAUGHAN SELF PRIMING CHOPPER PUMP
STARTUP AND CERTIFICATION CHECKLIST**

Email completed form to: STARTUP@CHOPPERPUMPS.COM

- Pump shaft turns freely by hand? Yes _____ No _____
- All guards are in place? Yes _____ No _____
- Motor adjusters are snug to base and set screws tight? Yes _____ No _____
- Pump is turning clockwise as viewed from the motor end? Yes _____ No _____
- Is the bearing oil level in the middle of the range of the site glass? Yes _____ No _____
- Is the seal oil reservoir full? Yes _____ No _____
- Is the pump housing filled with liquid? Yes _____ No _____
- Is there a bypass line on the discharge piping? Yes _____ No _____
- Is an air release valve (ARV) installed in the discharge piping? Yes _____ No _____
- If yes, is ARV located in high point before first check valve? Yes _____ No _____
- All piping attached to pump is being independently supported? Yes _____ No _____
- All piping joints are leak tight? Yes _____ No _____
- Flexible joint is connected to pump discharge? Yes _____ No _____
- If yes, is piping anchored between expansion joint and pump discharge, per H.I. standards? Yes _____ No _____
- Both suction and discharge valves open? Yes _____ No _____
- Construction debris in sump or piping? Yes _____ No _____
- Does Inflow splash down into sump? Yes _____ No _____

ELECTRICAL DATA

Motor Mfr: _____ Motor S/N _____

Motor HP: _____ Motor RPM: _____

Nameplate Voltage: _____ Nameplate F.L. Amperage: _____

Operating Voltage: L1 – L2 _____ L2 – L3: _____ L1 – L3: _____

Operating Amperage: L1: _____ L2: _____ L3: _____

SYSTEM DATA

What type of material are you pumping? _____

Temperature (°F): _____ Specific Gravity: _____ %Solids: _____

Elevation change from water level to pump suction centerline (feet) _____

Suction pipe size (inch): _____ Total equivalent length of suction pipe (feet): _____

Is a suction bell used? Yes _____ No _____ If yes what is suction bell diameter? _____ inch

Discharge pipe size (inch): _____ Total equivalent length of discharge pipe (feet): _____

Elevation change from pump suction centerline to discharge point (feet) _____

Estimated Total Head (feet): _____ Design Flow (GPM): _____

PUMP OPERATING DATA

Pump Model: _____ Impeller Diameter: _____

Height Z1 _____ feet

Discharge Pressure (fill in psi): **Pump Off (psi):** _____ **Pump On (psi):** _____

Dim Z2 (distance from pump suction centerline to discharge pressure gauge): _____ feet

Suction Pressure (fill in psi or in. Hg in negative): **Pump Off (psi):** _____ **Pump On (psi):** _____

Dim Z3 (distance from pump suction centerline to suction pressure gauge): _____ feet

Observed Pump Flow (GPM): _____

Pump Speed: _____

Is pump running: Quietly _____ Noisily _____ Very Noisily _____

NOTE: *If pump is not running quietly, please contact us immediately for help. Severe vibration can damage the pump very quickly.*

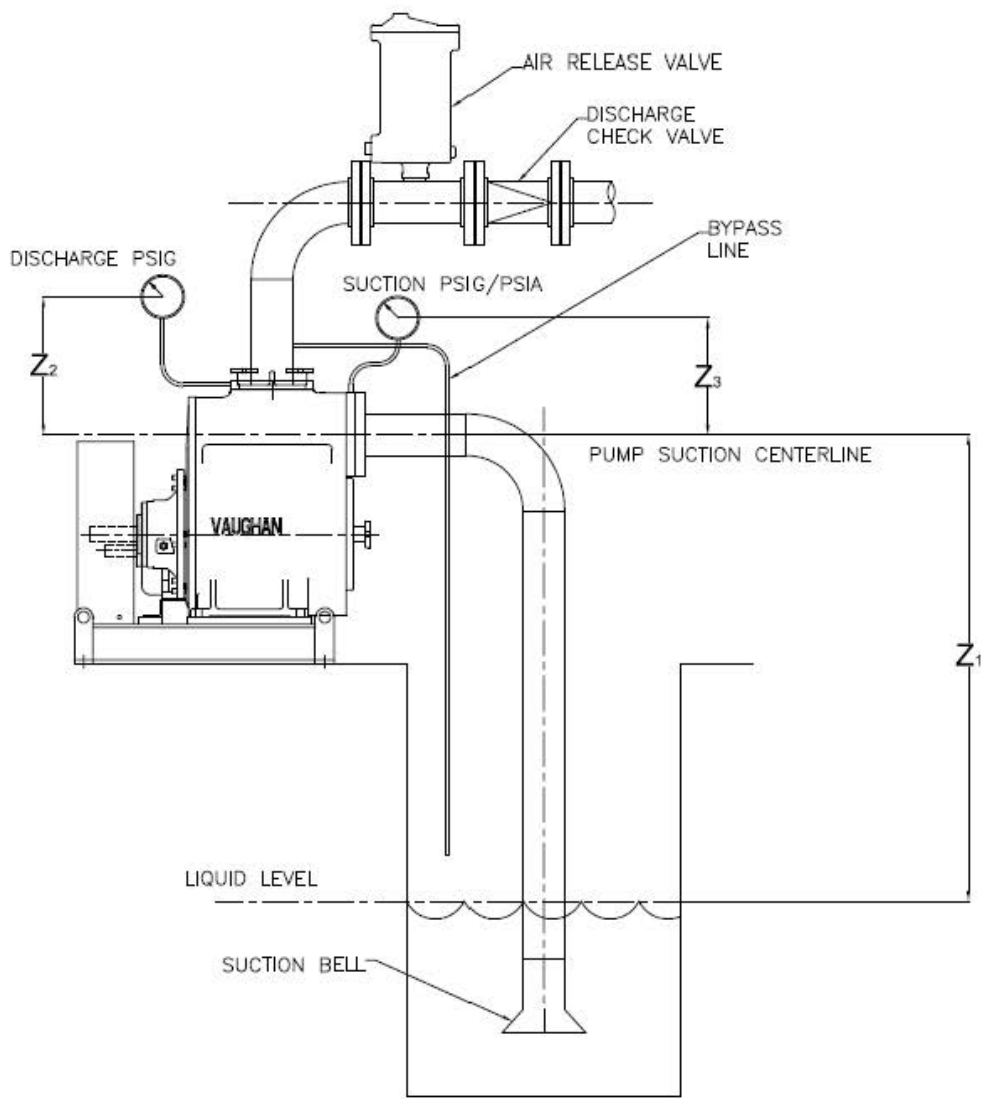

SELF PRIMER START UP DWG. #120229 REV. 0 12/27/18

SECTION 5: NORMAL PUMP OPERATION

A. NOISE

Most Vaughan pumps operate at either 1170 or 1750 RPM. At these speeds, the pump is normally quiet running, and the major source of noise is the electric motor. (Higher horsepower, higher head pumps, of course, are noisier.) Sometimes at startup a tank may be full of debris, and the pump will be fairly noisy due to chopping it. This noise should dissipate as the debris is broken up and/or pumped out.

B. VIBRATION

Vibration, like noise, should be minimal in the pump unless the pump is doing heavy chopping. If a particularly tough rag, or nylon pantyhose gets caught in the pump, temporary dynamic imbalance and some flow blockage will occur until the rag is chopped up and cleared. These conditions will create an unbalance and vibration. This condition is generally short-lived, and the chopping action of the pump normally clears the obstruction in a short time.

Please note that every effort has been made at the factory to ensure that these pumps operate smoothly and within Hydraulic Institute Standard vibration limits. All impellers are dynamically balanced after impeller machining to 1 mil. or less of imbalance. The pump shaft is fully machined to be straight and is tightly held by bearings so that there is virtually no shaft movement. Your pump should not exhibit any significant vibration or noise in normal operation. If you feel that the pump is noisy or vibrating more than it should, please call Vaughan Company immediately to discuss. Excessive vibration and/or noise may be indicative of system mismatch or other problem that could severely shorten the life of your pump.

C. SEAL OIL SYSTEM

It is not unusual for the seal oil reservoir to become contaminated with pumpage over several months of operation. The purpose of the oiler is to lubricate and cool the seal faces, so slight contamination is not a problem unless the oil in the reservoir is no longer a good lubricant or is likely to foul the insides of the mechanical seal. The oil can be easily changed by removing the drain plug at the bottom of the bearing housing. If leakage into the seal oil reservoir is severe, so that material is flowing out the vent onto your floor, then the mechanical seal probably needs to be replaced.

Vaughan Co. uses Chevron Rando HD-46 which is ISO 46 hydraulic oil. Most ISO 46 hydraulic oils and ISO 46 turbine oils should be compatible with Rando HD 46 supplied in our pumps.

D. PRESSURE RELIEF VALVE

Self-priming pumps are sent from Vaughan supplied with a pressure relief valve. This is a safety feature designed to relieve dangerous pressures in the event that they should build up in the housing; this could occur if the pump is having difficulty priming, such as if there were an air leak in the suction line or if air is not properly vented from the discharge line. Please ensure that the pump is allowed to fully cool before removing any covers and performing any maintenance.

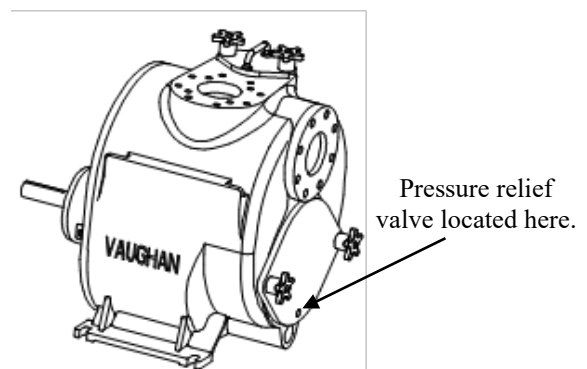

⚠ WARNING

High temperature and pressure and temperature is possible inside the pump. Lockout power and let the pump cool to ambient temperature before opening any covers or plugs. Do not operate without the pressure relief valve installed.

E. BYPASS LINES

During normal operation, any air that must be vented from the system will flow through the bypass line until the pump is fully primed. Even after priming, liquid will continue to flow through the bypass line back to the wet well.

NOTICE

The bypass line must be installed before the discharge check valve for proper operation.

CAUTION

If no bypass line is used the pump must discharge to atmosphere. A check valve cannot be used in the discharge line because it won't open and the pump will overheat. This will damage the pump and create a hazard to personnel.

NOTICE

If a manual shut-off valve is used with a bypass line, it must remain open during normal operation of the pump. If the pump should need to re-prime, either due to automatic restart or a pocket of air, the valve must be open in order to release any air from the system.

F. COLD WEATHER PRESERVATION

Special precautions should be taken when temperatures fall below freezing to ensure that liquid inside the casing will not freeze and damage any of the rotating parts. Drain the pump completely. Flush the inside the pump casing with a hose to remove any solids that may have accumulated at the bottom of the casing. Operate the pump for approximately 1 minute to remove any remaining liquid from the rotating parts. Spray the impeller and the cutter bar with oil for storage.

SECTION 6: SHUTDOWN INSTRUCTIONS

A. MANUAL SHUTDOWN

In the manual mode of operation, a Vaughan pump is shut down by hitting the "off" button or turning the auto/man/off switch to the "off" position on the front panel of your control panel. If any repair or maintenance work is to be done on the pump, be sure to follow all the warnings at the beginning of this manual.

B. AUTOMATIC SHUTDOWN

Automatic operation normally shuts the pump down for you, usually on low pit level. If the pump does not shut down when the pit is pumped out, the pump may be shut down manually, but you will want to troubleshoot your level control system to find out why the auto operation is working improperly. If you are going to do any maintenance, adjustment or inspection on this pump or motor, be sure to follow all warnings at the beginning of this manual. Be sure to turn off electrical power by opening the main panel breaker and by following all plant safety procedures, since in the automatic mode, the pump could start automatically if not isolated!

When the pump has been shut down on low pit level, liquid will be retained in the self-priming pump housing with an internal suction-side check valve. As long as this suction check valve does not leak significantly, the next time the pump starts up on pit high level, very little pump priming will be needed and pumping downstream should begin as soon as the pump starts. If the valve leaks, then priming will have to again take place before pumping starts.

C. EMERGENCY SHUTDOWN

In any kind of emergency when the pump needs to be shut down, hit the manual off switch or push-button on the front of the pump control panel. If any work has to be done on the pump or motor, open the main breaker on the pump control panel so that the pump cannot automatically restart when personnel are near the pump or motor.

SECTION 7: MAINTENANCE

During the time that the pump is priming and removing air from the system, water is being recirculating back through the transfer port in the casing back to the low-pressure region in the impeller. Here, the water mixes with more air and work is done on it by the impeller. This ongoing recirculation causes the liquid to absorb increasing amount of energy, and it gets hot.

Due to this action, it is possible for **very high temperatures and pressures** to build up inside the pump housing. This is especially true if the pump has taken a long time to prime, or is unable to prime.

⚠ DANGER

Do not open covers or plugs until pump has fully cooled. High temperature and pressure in the pump can cause severe burns and injury to personnel.

For these reasons, you should always assume that high pressures and/or temperatures could be present. **Before attempting to service or inspect the pump, be sure to comply with the following:**

- 1) Disconnect or lock out power source.
- 2) Allow pump to cool fully. Vapor pressure inside the pump can cause parts to be ejected with great force. Pumped liquids may be extremely hot.
- 3) Close suction and discharge valves to isolate the pump from the system.
- 4) Vent the pump slowly after pump has cooled.
- 5) Drain the pump by removing drain plug at bottom of casing.

A. ROUTINE MAINTENANCE

⚠ WARNING

Isolate the pump hydraulically and electrically before servicing or inspecting the pump. Lock out both power source and isolation valves. Never clean oil, adjust, or repair machinery while in motion. Appropriate personal protective equipment should always be worn when servicing Vaughan pumps

MONTHLY:

1. Check amperage draw to the pump motor and compare to that measured at startup. Make sure that power draw does not exceed allowable amperage to the motor at full load.
2. Check level and condition of oil in the seal oil reservoir. If it is contaminated, change the oil. Use ISO 46 hydraulic oil. Contamination of the seal oiler reservoir is not a serious problem unless liquid is overflowing onto the floor.

QUARTERLY:

1. Motor: Inspect electric motor. Make sure that casing drain is not plugged to ensure that motor cannot fill up with water. Clean cooling fins so that dirt buildup will not affect cooling ability of motor. Check for loose hardware and damaged wiring or conduit.
2. Pump: Inspect pump for loose hardware. Make sure that pump is operating smoothly and without vibration.
3. Check oil level in pump bearing housing and check for oil contamination.
4. Grease motor bearings with bearing grease as specified by the manufacturer
5. Perform monthly inspection as shown above.

SEMIANNUALLY:

1. Perform all quarterly inspections as shown above.
2. Manually check pressure relief valve for proper operation.

- Isolate the pump electrically (open breakers) and mechanically (close suction & discharge valves) and then remove the suction manifold access cover to look for any suction-side blockage.

ANNUALLY:

The clearance between the impeller and the cutter bar should be checked to ensure proper cutting action and best efficiencies. During normal operation, normal wear will gradually increase the gap between the impeller and the cutters. These gaps can be readjusted without any pump disassembly.

The entire rotating assembly, including the impeller and the bearing housing, moves in and out of the casing to adjust the impeller-to- cutter bar gap.

TO ADJUST:

If a belt drive is being used, relieve belt tension before making any adjustments.

- Loosen and back off each of the clamp bolts on the bearing housing flange, ensuring that the adjusting sleeves do not move with the bolts. Choose three evenly spaced adjusters at approximately 120° intervals that you will use to perform the adjustments. It is useful to witness mark the starting position of each of your three chosen adjusters to track your adjustments as you proceed. Back the other three adjusting sleeves away from the back cover by turning them counter clockwise.
- Using a piece of 1/4" key stock as a feeler gauge, equalize the gap between the rotating assembly and back cover at each of the three chosen adjustment sleeves. This will ensure that you have a consistent gap all around, and will bring the impeller square to the cutter bar.
- Turn the three adjusting sleeves **evenly** one flat **counterclockwise**, then tighten the clamp bolts in the three adjusting sleeves. This will pull the rotating assembly forward in the pump housing, thereby moving the impeller closer to the cutter bar. Each flat of rotation will reduce the impeller to cutter bar gap by .010 inch. Check for interference by manually rotating the shaft. Repeat this procedure until you attain light contact between the impeller and cutter bar.
- Once light contact is attained with the clamp bolts tight, loosen the clamp bolts again and turn the adjusters two flats **clockwise**, then tighten the clamp bolts. This will give the proper operating clearance of .020 inch. Don't make the clearance tighter than this, because as the pump warms up the shaft will grow slightly and this clearance will shrink.
- After all bolts have been securely tightened, check for smooth shaft rotation by rotating the pump shaft again by hand. If the proper clearance cannot be achieved, or if other damage requires it, the impeller and cutter bar may need to be replaced. If this becomes necessary, refer to

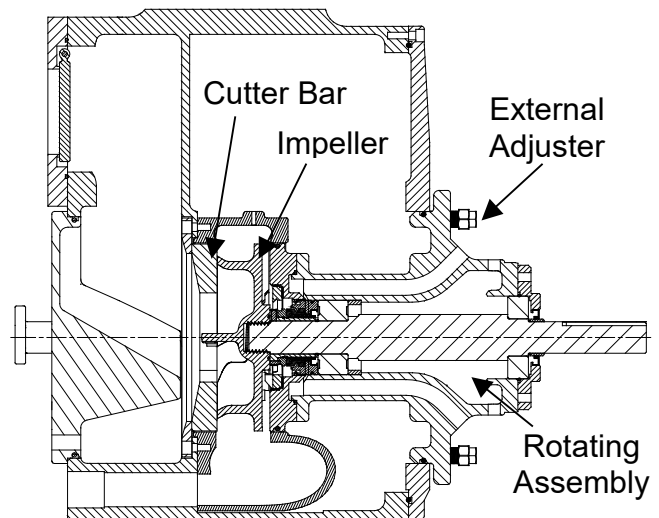
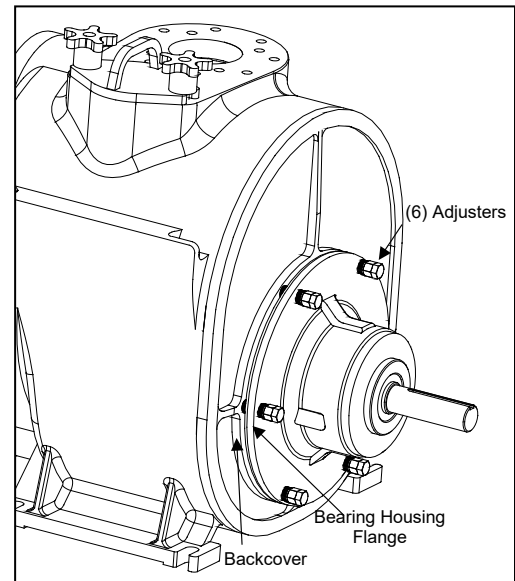

NOTE: One full turn of adjuster is equal to .063". Turning the adjuster one flat, or one "point" is equal to .010".

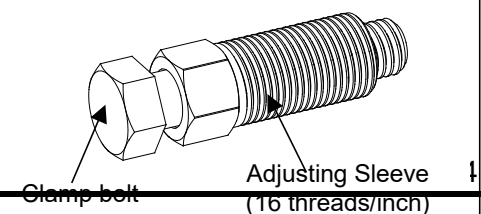

the overhaul manual for the proper procedures for this operation.

B. CORRECTIVE MAINTENANCE

Because overhaul of a Vaughan self-priming chopper pump is a major undertaking, Overhaul Instructions is a separate procedure. Please do not try to overhaul or repair the pump without this important procedure and without the exploded assembly parts breakdown. The overhaul manual was sent with your pump from the factory, but if you do not have a copy of this manual, please call Vaughan Co. Engineering and we will make sure you get proper instructions overnight.

For more information, please visit our website at <http://www.chopperpumps.com>

SECTION 8: TROUBLESHOOTING

The Vaughan Self-Priming Chopper pump is more susceptible to system problems than Vaughan Wet-Well or Submersible pumps because piping is attached to the pump suction, a situation which can allow “starving” of the pump, before material has a chance to get to the pump.

While Vaughan’s Self-Priming design has obvious advantages over other types of horizontal pumps, problems can still occur. On the following page is a troubleshooting chart that will help you get some idea of what symptoms could cause what problems. If you would like help, please call Vaughan Co. Engineering for troubleshooting help. We will be glad to offer assistance.

		SYMPTOMS										
		Low Discharge Pressure	Loss of Prime or Unable to Prime	Seal Oil Contamination	Excessive Power Required	Severe Pitting of Impeller/Cutter Bar	Short Seal Life	Abnormally High Vibration	Short Bearing Life	Pump Casing Overheating	High Bearing Temp.	Broken Shaft
POSSIBLE PROBLEMS												
SUCTION PROBLEMS	Air Pockets in Suction Line		✓	✓				✓				✓
	Housing Not Properly Filled with Water	✓	✓					✓	✓			✓
	Insufficient NPSH	✓	✓	✓		✓	✓	✓				✓
	Suction Line Air Leaks / Cracks in PVC Fittings		✓	✓				✓				✓
	Suction Check Valve Plugged	✓	✓									
	Vortexing in Pit at Inlet	✓	✓	✓			✓	✓				✓
	Intake Openings Plugged	✓	✓	✓			✓	✓		✓		✓
SYSTEM PROBLEMS	Pump Speed High or Impeller Dia. Too Large			✓	✓		✓	✓	✓			
	Pump Speed Low or Impeller Dia. Too Small	✓	✓	✓				✓		✓		✓
	Bypass/Vent on Discharge Plugged /Not Installed		✓							✓		
	Pump Rotation Incorrect	✓	✓	✓	✓		✓	✓				✓
	Discharge Head Too High		✓	✓		✓	✓	✓	✓			✓
	Suction Lift Too High	✓	✓							✓		✓
	Discharge Head Too Low	✓	✓	✓	✓		✓	✓	✓			
	Specific Gravity Higher than Expected				✓							
	Viscosity Higher than Expected	✓	✓		✓							✓
	Operation at Low Capacity			✓			✓	✓	✓	✓		✓
	Improper Parallel Operation of Pumps	✓		✓			✓	✓		✓		✓
Improper Series Operation of Pumps			✓			✓						
MECHANICAL PROBLEMS	Pump Discharge Blocked			✓		✓	✓	✓	✓	✓	✓	✓
	Misalignment of Pump/Driver			✓	✓		✓	✓	✓		✓	
	Foundation not Rigid						✓	✓	✓			
	Worn Bearings			✓	✓		✓	✓		✓		
	Motor adjusters not snug to base							✓				
	Bent Shaft			✓			✓	✓	✓			
	Rotating Mbr Contacts Stationary Mbr						✓	✓	✓	✓		✓
	Cutter Bar or Impeller Worn	✓	✓		✓			✓				✓
	Impeller Damaged or Loose on Shaft	✓	✓	✓	✓		✓	✓			✓	✓
	Shaft Running Off Center			✓		✓		✓	✓	✓	✓	
	Lack of Lubrication				✓		✓	✓	✓		✓	
	Improper Repair/Installation of Bearings			✓	✓		✓	✓	✓		✓	
	Dirt in Bearings						✓	✓	✓		✓	
	Shaft Sleeve Worn or Scored		✓	✓			✓					
	Dirt or Grit in Sealing Fluid			✓			✓					
Overfill of Bearing Housing								✓		✓		



VAUGHAN CO., INC. PRODUCT WARRANTY

Vaughan Company, Inc. (Vaughan Co.) warrants to the original purchaser/end user (Purchaser) all pumps and pump parts manufactured by Vaughan Co. to be free from defects in workmanship or material for a period of twelve (12) months from date of startup, not to exceed eighteen (18) months from the date of shipment from Vaughan Co. Startup data must be submitted to Vaughan Co. within 30 days of startup. If Purchaser fails to submit startup data within 30 days of startup, then Vaughan, in its sole discretion, may elect to void this warranty at any time. Purchaser must contact Vaughan Co. prior to commencing any repair attempts, or removing pump or parts from service. If Purchaser fails to contact Vaughan Co. prior to commencing any repair attempts or removing pumps or parts from service, then Vaughan, in its sole discretion, may elect to void this warranty at any time.

If during said warranty period, any pump or pump parts manufactured by Vaughan Co. prove to be defective in workmanship or material under normal use and service, and if such pump or pump parts are returned to Vaughan Co.'s factory at Montesano, WA, or to a Vaughan authorized Service Facility, as directed by Vaughan Co., transportation charges prepaid, and if the pump or pump parts are found to be defective in workmanship or material, they will be replaced or repaired by Vaughan Co. free of charge. Products repaired or replaced from the Vaughan Co. factory or a Vaughan authorized Service Facility under this warranty will be returned freight prepaid. Vaughan Co. shall not be responsible for the cost of pump or part removal and/or re-installation.

All warranty claims must be submitted in writing to Vaughan Co. not later than thirty (30) days after warranty breach occurrence. The original warranty length shall not be extended with respect to pumps or parts repaired or replaced by Vaughan Co. under this Warranty. This Warranty is voided as to pumps or parts repaired/replaced by other than Vaughan Co. or its duly authorized representatives.

Vaughan Co. shall not be liable for consequential damages of any kind, including, but not limited to, claims for property damage, personal injury, attorneys' fees, lost profits, loss of use, liability of Purchaser to customers, loss of goodwill, interest on money withheld by customers, damages related to third party claims, travel expenses, rented equipment, third party contractor's fees, or unauthorized repair service or parts. The Purchaser, by acceptance of delivery, assumes all liability for the consequences of the use or misuse of Vaughan Co. products by the Purchaser, its employees or others.

Equipment and accessories purchased by Vaughan Co. from outside sources which are incorporated into any Vaughan pump or any pump part are warranted only to the extent of and by the original manufacturer's warranty or guarantee, if any, which warranty, if appropriate, will be assigned by Vaughan Co. to the Purchaser. It is Purchaser's responsibility to consult the applicable product documentation for specific warranty information. Specific product documentation is available upon request. Any warranty shall be void if the total contract amount is not paid in full.

Vaughan Co. neither assumes, nor authorizes any person or company to assume for it, any other obligation in connection with the sale of its equipment with the exception of a valid Vaughan "Performance Guarantee" or "Extended Warranty," if applicable. Any other enlargement or modification of this warranty by a representative or other selling agent shall not be legally binding on Vaughan Co.

Warranty eligibility determination is at Vaughan Co.'s sole discretion.

Warranty Limitations:

This warranty shall not apply to any pump or pump part which has been subjected to or been damaged by any of the following non-exclusive list of causes:

- Misuse
- Abuse
- Accident
- Negligence
- Operated in the dashed portion of the published pump curves
- Used in a manner contrary to Vaughan's printed instructions
- Defective power supply
- Improper electrical protection
- Improper storage
- Faulty installation, maintenance, or repair
- Wear caused by pumping abrasive or corrosive fluids or by cavitation
- Dissatisfaction due to buyer's remorse
- Damages incurred during transportation
- Damages incurred during installation or maintenance

THIS IS VAUGHAN CO.'S SOLE WARRANTY AND IS IN LIEU OF ALL OTHER WARRANTIES, EXPRESSED OR IMPLIED, WHICH ARE HEREBY EXCLUDED INCLUDING IN PARTICULAR ALL WARRANTIES OF MERCHANTABILITY OR FITNESS FOR A PARTICULAR PURPOSE.

