



8" VERTICAL RECIRCULATOR CHOPPER PUMPS

Materials of Construction:

Impeller/Upper Cutter/External Cutter:	Cast alloy steel, heat treated to minimum Rockwell C 60.
Cutter Bar/Wear Plate:	Alloy steel, heat treated to minimum Rockwell C 60.
Casing/Back Pull-Out Plate:	Ductile cast iron.
Mechanical Seal:	Cartridge type with silicon carbide (or tungsten carbide) faces and stainless steel sleeve.
Thrust Bearings:	Back-to-back angular contact ball type or tapered type.
Radial Bearings:	Ball type.
Shaft:	Heat treated alloy steel.
Lubrication:	ISO Grade 46 oil.
Discharge Flange:	ANSI Class 150.
Mounting Plate:	Carbon steel.
Paint:	Epoxy.

DRAWINGS AND DIMENSIONS SUBJECT TO CHANGE WITHOUT NOTICE. DO NOT USE FOR CONSTRUCTION PURPOSES. CONTACT VAUGHAN FOR CERTIFIED CONSTRUCTION PRINTS.

MODEL	A	B	C	D	E	F	G	J	K	L
V8NR	37-5/8	58-1/2	66	48	8	23-1/4	15-5/8	1	66	7/8

DIMENSIONS IN INCHES

HP	SPEED	FRAME	H*
15	870	286TC	35
20	870	324TC	37
25	870	326TC	38
	1170	324TC	37
30	870	364TC	42
	1170	326TC	38
40	870	364TC	42
	1170	364TC	42
50	870	405TC	48
	1170	365TC	42
60	1170	404TC	46
75	1170	405TC	48
100	1170	444TC	53
125	1750	405TC	48
	1750	444TC	53
150	1750	445TC	53
	1750	447TC	56
200	1750	447TC	56
250	1750	447TC	56

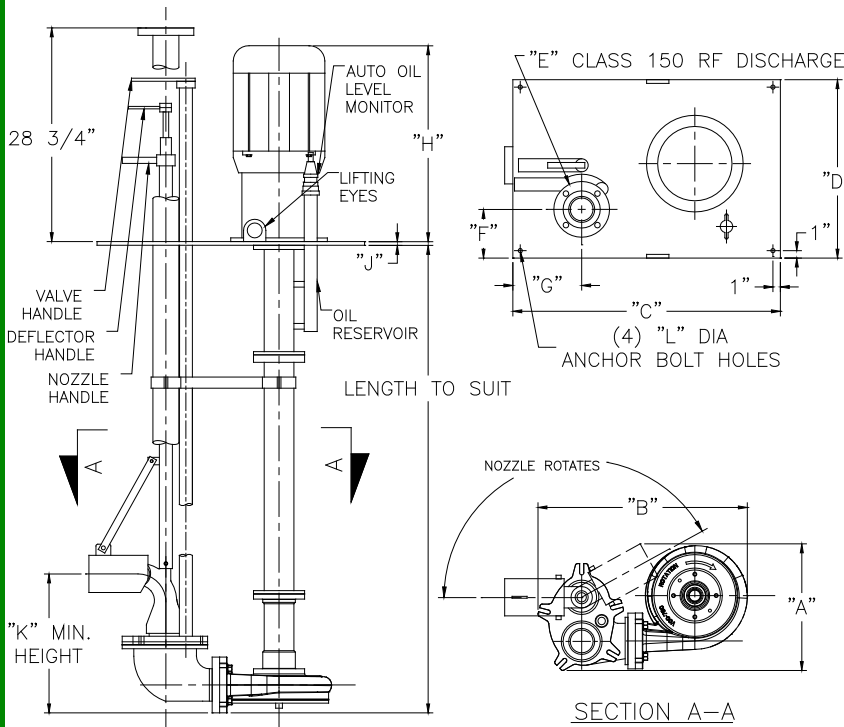

*FOR REFERENCE ONLY DIMENSION WILL VARY SLIGHTLY WITH MOTOR MANUFACTURER.



VAUGHAN CO., INC.
 364 Monte Elma Road, Montesano, WA 98563
 Phone: 1-360-249-4042 / Fax: 1-360-249-6155
 Toll Free Phone (US only): 1-888-249-CHOP (2467)
 Web Site: www.chopperpumps.com
 Company E-mail: info@chopperpumps.com

**MADE IN THE
USA**

For all current patents, see <http://www.chopperpumps.com/patents.htm>

SPECIFICATIONS – 8” VERTICAL RECIRCULATOR CHOPPER PUMPS

The Vendor shall furnish one vertical wet pit chopper pump and all appurtenances as specified. The pump shall be specifically designed to pump waste solids at heavy consistencies. Materials shall be macerated and conditioned by the pump as an integral part of the pumping action. The pump must have demonstrated the ability to chop through and pump high concentrations of solids such as plastics, heavy rags, grease and hair balls, wood, paper products and stringy materials without plugging, both in tests and field applications

DETAILS OF CONSTRUCTION

- A. Casing, Back Pull-Out Adapter Plate and Wear Plate:** The pump casing shall be of volute design, spiraling outward to the flanged centerline discharge. A ½"-NPT pressure tap shall be included on or near the discharge flange. Back pull-out adapter plate shall allow removal of pump components from outboard of the casing, and allow external adjustment of impeller-to-cutter bar clearance. Casing and adapter plate shall be ductile cast iron with all water passages to be smooth, and free of blowholes and imperfections for good flow characteristics. Backplate will include a replaceable Rockwell C 60 alloy steel wear plate with back cutter adjustable for 0.030-0.050" clearance to cut against the rotating impeller pumpout vanes for removing fiber and debris.
- B. Impeller:** Shall be semi-open type with pump out vanes to reduce seal area pressure. Chopping/maceration of materials shall be accomplished by the action of the cupped and sharpened leading edges of the impeller blades moving across the cutter bar at the intake openings, with a set clearance between the impeller and cutter bar of 0.015" - 0.025". Impeller shall be cast alloy steel, heat treated to minimum Rockwell C 60 and dynamically balanced. The impeller shall be threaded to the shaft and shall have no axial adjustments and no set screws.
- C. Cutter Bar Plate:** Shall be recessed into the pump bowl and shall contain at least 2 shear bars extending diametrically across the intake opening to within 0.025" - 0.050" of the rotating external cutter tooth, for the purpose of preventing intake opening blockage and wrapping of debris at the shaft area. Chopper pumps utilizing individually mounted shear bars, and which do not have a rotating external cutter extending through to the opposite side of the shear bar, shall not be acceptable. Cutter bar shall be alloy steel heat-treated to minimum Rockwell C 60.
- D. Upper Cutter:** Shall be threaded into the wear plate behind the impeller, designed to cut against the pump-out vanes and the impeller hub, reducing and removing stringy materials from the mechanical seal area. Upper cutter shall be cast alloy steel, heat treated to minimum Rockwell C 60. The upper cutter teeth are positioned as closely as possible to the center of shaft rotation to minimize cutting torque and nuisance motor tripping. The ratio of upper cutter cutting diameter to shaft diameter in the upper cutter area of the pump shall be 3.6 or less.
- E. External Cutter:** The external cutter shall be used to eliminate binding or build-up of stringy materials at the pump inlet. The external cutter shall consist of opposing cutter wings which shear against the outside surface of the shear bars and the anvil, an integral cast tooth which shears against the adjacent surface of the shear bars, and a hex head sufficiently sized for ease of removal. The external cutter shall be cast alloy steel and heat treated to a minimum Rockwell C 60.
- F. Recirculation Nozzle Assembly:** The pump shall be fitted with a recirculation nozzle assembly to permit recirculation/conditioning of the pit contents prior to discharge. The recirculation nozzle shall be adjustable minimum 180° horizontally and 35° vertically. A valve assembly shall be connected to the pump discharge to adjust pump flow either to the nozzle or the pump discharge flange. Valve shall be carbon steel, with 316 SS valve disk. The operating levers shall be located above at a mounting plate for easy access.
- G. Optional Automatic Valve Actuator:** An electrically operated valve actuator shall position the valve for pump out or mixed operation. A ball screw linear actuator shall be used to provide valve positioning. Unit shall operate on 110V or 220V AC, single-phase power with 25% duty cycle, and shall be capable of producing 500 pounds of actuation force, with a freewheeling feature to prevent over travel at the end of stroke. A capacitor for single phase-motor starting shall be included in the design. All components shall be housed in an enclosure suitable for outdoor operation. Includes a limit switch for indicating valve recirculation or discharge positions. External controls, housed in a separate control unit (by others), are required to indicate valve position
- H. Pump Shafting:** Shall be 2-7/16" diameter minimum. Lower stub shaft shall be heat treated. Upper shaft extension shall be turned, ground and polished. The shaft column shall be minimum 6" schedule 40 steel pipe welded to steel flanges and machined with piloted bearing fits for concentricity of all components. All support column tubes shall be leak tested. Distance between shaft bearings shall not exceed critical speed dimensions.
- I. Pump Shaft Bearings:** Shall be oil bath lubricated by I.S.O. Grade 46 oil, with the exception of the top bearing, which shall be grease packed. The bearings shall have a minimum L-10 life rated 100,000 hours. Shaft thrust shall be taken up by two back-to-back mounted single row angular contact ball bearings, or tapered roller bearings which bear against a machined shoulder on one side and the seal sleeve on the other side. Overhang from the centerline of the lower thrust bearing to the seal faces shall be a maximum of 2.75", with a mechanical seal to isolate the bearings from the pumped media.
- J. Mechanical Seal:** The mechanical seal shall be located immediately behind the impeller hub to maximize the flushing available from the impeller pumpout vanes. The seal shall be a screw-in, cartridge-type mechanical seal with Viton O-rings and silicon carbide (or tungsten carbide) faces. This cartridge seal shall be a pre-assembled, pre-tested so that no seal settings or adjustments are required from the installer. Any springs used to push the seal faces together must be shielded from the fluid to be pumped. The cartridge shall also include a 17-4PH, heat-treated seal sleeve and a ductile iron seal gland.
- K. Automatic Oil Level Monitor:** Shall be located above the mounting plate and be fitted with an internal oil level switch to detect oil level and shut off the motor in event of low oil level. A relay shall be included for mounting in the motor control panel.
- L. Pump Discharge Pipe:** The pump assembly shall be mounted vertically on a common steel base plate with Class 150 discharge flange. A 1/4" NPT pressure tap shall be located above the deck plate.
- M. Shaft Coupling:** Shall be T.B. Woods Sureflex elastomeric type with a minimum 1.5 service factor based on the drive rated horsepower, and shall be protected with a guard meeting OSHA requirements.
- N. Motor Stool:** Shall be a fabricated carbon steel weldment machined with piloted fits to positively align the C-flanged motor and pump shaft, with no adjustments.
- O. Pump Deck Plate:** Shall be fabricated carbon steel, 1" minimum thickness, and shall include lifting lugs.
- P. Stainless Steel Nameplate:** Shall be attached to the pump giving the manufacturer's model and serial number, rated capacity, head, speed and all pertinent data.
- Q. Motor Requirements:** Drive motor shall be ___ HP, ___ RPM, ___ volts, 3 phase, 60 hertz, 1.15 service factor, TEFC enclosure. The motor shall be sized for non-overloading conditions.
- R. Surface Preparation:** Solvent wash and coated with 5-8 MDFT epoxy (except motor).
- S. OPTIONAL Surface Preparation:** Commercial sandblast (except motor), primed with 5-8 MDFT epoxy primer and finish coated with 5-8 MDFT epoxy (except motor).