

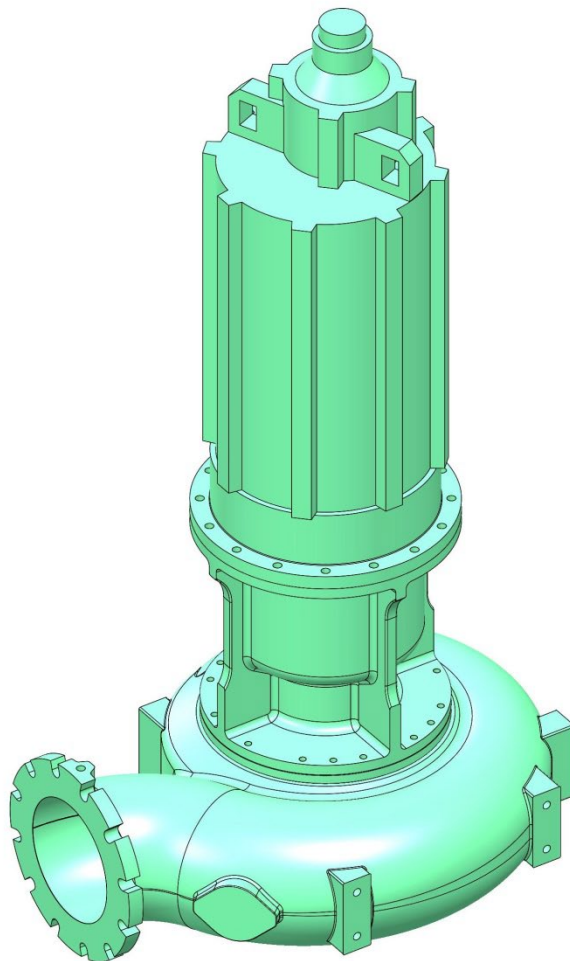

S-SERIES ELECTRIC SUBMERSIBLE PUMPS

INSTALLATION, OPERATION & MAINTENANCE INSTRUCTIONS



VAUGHAN CO., INC.

364 Monte Elma Road, Montesano, WA 98563
Phone: 1-360-249-4042 / Fax: 1-360-249-6155
Toll Free Phone (US only): 1-888-249-CHOP (2467)
Web Site: www.chopperpumps.com
Company E-mail: info@chopperpumps.com

INSTALLATION, OPERATION & MAINTENANCE INSTRUCTIONS

TABLE OF CONTENTS

SAFETY INFORMATION	Page 1
DESCRIPTION OF SUBMERSIBLE CHOPPER PUMP	Page 3
A. Description of Major Pump Components	
B. Proper Applications for Vaughan Chopper Pumps	
C. Use of Vaughan Pumps That May Cause Trouble	
D. Expected Benefits of Vaughan Pumps	
INSTALLATION INSTRUCTIONS	Page 7
A. Receipt Inspection	
B. Storage Considerations	
C. Mounting the Pump and Guiderail System in your Pit	
D. Piping	
E. Controls	
F. Baldor Submersible Motor	
G. Automatic Oil Level Monitor	
PUMP STARTUP INSTRUCTIONS	Page 14
NORMAL OPERATION OF PUMP	Page 20
SHUTDOWN INSTRUCTIONS	Page 21
A. Manual Shutdown	
B. Automatic Shutdown	
C. Emergency Shutdown	
MAINTENANCE	Page 21
A. Routine Maintenance	
B. Corrective Maintenance	
TROUBLESHOOTING	Page 23
WARRANTY	Page 25

SECTION 1: IMPORTANT SAFETY INFORMATION

IMPORTANT INFORMATION FOR INSTALLERS OF THIS EQUIPMENT!

This equipment is intended for installation by technically qualified personnel. Failure to install it in compliance with national and local electrical codes, building codes and within Vaughan Co. recommendations may result in electrical shock, personal injury or death, fire hazard, unsatisfactory performance, and equipment failure. If further assistance is required contact your local representative or Vaughan Co. *Keep this manual in a safe location for future reference.*

⚠ DANGER Indicates a hazard, which, if not avoided, will result in death or serious injury.

⚠ WARNING Indicates a hazard, which, if not avoided, could result in death or serious injury.

⚠ CAUTION Indicates a hazard, which, if not avoided, may result in minor or moderate injury or damage to the equipment.

NOTICE Indicates special operation or maintenance information.

- Isolate the pump hydraulically and electrically before servicing or inspecting pump. Lock out both power source and isolation valves.
- This pump may handle dangerous or contaminated fluids. There are sharp corners, edges and pinch areas which can cause serious injury. Be careful; wear protective gloves whenever possible. If you cut yourself, seek medical help immediately to avoid serious infection.
- This pump may start automatically if wired to float switches or other equipment. Before inspecting or making adjustments disconnect electrical power and lock out circuit breakers to pump motor and associated equipment. Duplex pumps with alternating relays must both be locked out; otherwise the pump you are working on may not be isolated and could start as “the alternate”. Visually confirm that the pump has come to a complete stop before proceeding.
- Motors may be equipped with built-in thermal overloads to shut off the motors in the event the temperature gets too high (as a result of low voltage, poor ventilation, overloaded lines, etc.) These motors can restart automatically as the motor cools down. DO NOT work on the pump or motor without first disconnecting and locking out the power supply.
- Enter tanks or pits with extreme caution and only after an instrument check of the pit/tank has been completed to verify the absence of dangerous gases and the presence of safe levels of oxygen. Never enter a tank or pit without a safety harness and lifeline, and an air pack. Never enter the pit without rescue personnel standing by. Follow all national and local requirements for confined space entry.
- Keep all pit openings covered when not in use. In addition to the injuries from falling, pits may contain poisonous gases or liquids.
- Lift pump and motor by pump lifting bail only. Lifting by any other parts of this equipment is dangerous and may damage equipment. Inspect the lifting bail to be sure it is not damaged. Replace immediately if the bail is weakened in any way.
- Do not allow people under the pump assembly while it is being lifted.
- Pump components can be heavy. Proper methods of lifting must be employed to avoid physical injury and/or equipment damage. Steel toed shoes should be worn at all times.
- Do not allow liquid to be trapped in pump or piping between two closed valves. Always drain or vent the piping/pump between two closed valves. Failure to vent or drain could allow dangerous pressures to build causing rupture damage resulting in injury, death, and equipment damage.
- Never operate a pump with closed or blocked discharge valves. This will destroy the pump and could be dangerous to personnel.
- Do not operate this equipment unless safety guards or devices are in place and properly adjusted.
- Let the pump cool to ambient temperature before beginning work on it. A warm pump can contain compartments of pressurized fluid, which may vent violently during disassembly.
- Shut pump off when adjusting fittings to avoid being sprayed with pumpage. Pumped materials may be hot, corrosive, poisonous, infectious, or otherwise dangerous to personnel.
-

- Safety apparel to be worn when working on or making adjustments to pumps should include:
 - Heavy work gloves when handling parts with sharp edges, especially impellers.
 - Safety glasses (with side shields) for eye protection
 - Steel-toed shoes for foot protection when handling parts, heavy tools, etc.
 - Other personal protective equipment to protect against hazardous/toxic fluids and gases.
- Never apply heat to remove parts unless specifically directed to do so in overhaul instructions. Use of heat may cause an explosion due to trapped fluid, resulting in severe physical injury and property damage.
- Pressure may build up in the standard mechanical seals used in Vaughan pumps. Whenever checking or maintaining the oil in the Vaughan Cartridge Seal, or the welded metal bellows seal with seal oil chamber, make sure the pump and seal are cool to the touch. Use care when removing the oil chamber plugs and pressure relief valve, in case any residual pressure exists. If pressure exists, the plug could become a projectile and/or contaminated oil could spray.
- As it is possible to run Vaughan Chopper and Screw pumps dry, for quality assurance or troubleshooting reasons, it is extremely important to ensure suction and discharge connections are always properly guarded to prevent anything (i.e. foreign objects or pump parts) from being thrown from the pump as a projectile. All pumps must be run with suction and discharge piping in place, or blind flanges installed on suction and discharge connections. Blind flanges should be vented to avoid pressure build-up. Note that cast rotating parts could break if metal to metal contact occurs while the pump is running dry.
- Pump motors are connected to high voltage. Allow only qualified electricians to service this electrical equipment only in accordance with the latest revision of the National Electrical Code and other applicable requirements.
- Make certain all personnel are clear of equipment before operating.
- This equipment may not meet explosion proof requirements for hazardous environments unless specifically ordered for this purpose. Introducing non-explosion proof equipment into a hazardous environment as defined by the National Electrical Code can cause a dangerous explosion.
- This pump uses oil which, if spilled, can cause a slipping hazard and danger to personnel.
- Keep hands, feet and clothing away from moving machinery.
- Never clean, oil, adjust, or repair machinery while in motion.
- Keep electrical control panel area clear to avoid to avoid hazard to personnel. If a person should trip and fall into an open panel enclosure, serious electrical burns can result.
- Keep electrical control panel doors closed except to make adjustments or repairs by a qualified electrician.
- Overheated pumps can cause severe burns and injury. If overheating of pump casing occurs:
 - 1) Shut down pump immediately.
 - 2) Wait for pump to cool to air temperature.
 - 3) Slowly and cautiously vent pump at drain plug.
 - 4) Troubleshoot cause of overheating.

Do not Enter any Confined Manure Pits Without Either:

A self-contained air breathing apparatus (SCBA) and an approved harness/lifeline.

OR

1. Testing the air for hydrogen sulfide, combustible gases or methane, and oxygen with dependable and reliable equipment, **AND**
2. Constant and adequate ventilation of fresh air, **AND**
3. An approved harness/lifeline on the person entering the pit with at least two people outside the pit who are capable of pulling the person out of the pit if necessary, **AND**
4. An approved pulley and tripod or other suitably strong lifting system that will make it possible to remove a limp body from the pit.

If there are any questions regarding the safe and proper methods for operating or servicing this pump, please contact Vaughan Company for assistance.

SECTION 2: DESCRIPTION OF VAUGHAN SUBMERSIBLE CHOPPER PUMP

The Vaughan submersible chopper pump is specifically designed for pumping trash laden material from wet pits in industrial and municipal plants. The pump can be used in the recirculating mode of operation to mix the pit before pumpout. An add-on recirculation valve mounted on the guiderail elbow can be obtained from Vaughan Co. to enable recirculation. Material is chopped/macerated by the pump so that particle size is reduced and downstream plugging problems are reduced.

A) DESCRIPTION OF MAJOR PUMP COMPONENTS

Note: Please refer to the pump cross-section below and Figure C showing the submersible chopper pump mounted on Vaughan's guiderail system. These pictures will help you understand this section more fully.

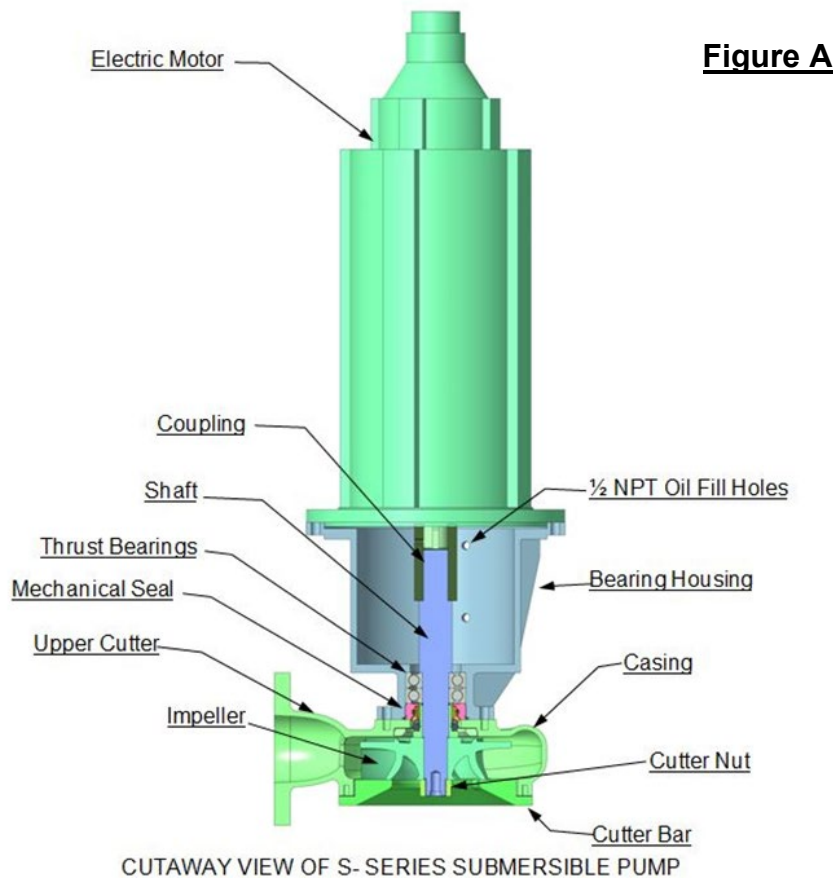

CHOPPER IMPELLER

The impeller on the Vaughan pump serves two purposes. It induces flow by propelling liquid material through the pump casing, and also chops solids by slicing against the cutter bar. The leading edge of each impeller blade is sloped forward to create a knife edge. As material enters the pump, it is caught and cut between the rotating knife edges on the impeller blades and the stationary bars of the cutter bar. The standard impeller is made of cast alloy steel and is heat treated to Rockwell C60.

CUTTER BAR

The cutter bar is a patented design that serves two functions. First, it serves the function of a "suction plate", sealing the intake of the pump. The pressure generated by the impeller is kept inside the pump by the close clearances between the cutter bar and the impeller. Second, the cutter bar includes two shear bars which span the entrance to the pump. Material is chopped by the pump impeller cutting against these stationary shear bars. The standard cutter bar is made of alloy steel and is heat treated to Rockwell C60.

CUTTER NUT

The cutter nut is a patented design that serves two purposes. First it secures the impeller to the shaft. Second the raised cutter tooth design prevents pump binding by cutting stringy materials that could otherwise wrap around the shaft and block the intake opening. The cutter nut is made of cast alloy steel heat treated to Rockwell C60. All 3-6" chopper pumps have a cutter nut.

EXTERNAL CUTTER (OPTIONAL ON 3-6" PUMPS)

The external cutter has opposing cutter wings that shear against the outside face of the cutter bar. It is used to prevent binding and buildup of stringy materials at the pump inlet. The external cutter is made of cast alloy steel, heat treated to Rockwell C60 and is standard on Chopper pumps 8" and larger.

UPPER CUTTER

The upper cutter is located behind the impeller and cuts against the pumpout vanes and the impeller hub to for the purpose of preventing stringy materials from wrapping in the mechanical seal area. The upper cutter is made of alloy steel heat treated to Rockwell C60.

DISINTEGRATOR TOOL

The disintegrator tool, not always used, is an auxiliary cutter located below the pump to help prevent inlet blockage. Matted material which tends to block the opening to the pump can be cut up or knocked away by this tool until flow can resume into the pump. The disintegrator tool is particularly helpful in manure and food-processing applications. However, it has the disadvantage that material which tends to wrap -- material like rags, hair, and fiber -- can ball up on the tool and eventually block flow into the intake openings of the pump. (Vaughan Co. does not recommend the use of a disintegrator tool whenever you are pumping sewage or sewage sludge.) If the pump is installed with a disintegrator tool and if suction blockage becomes a problem due to wrapping (problems usually show up as reduced flow or severe vibration), then the tool should be removed and replaced with a stainless steel set-screw available from Vaughan Co. Note that the cutter nut holds the impeller onto the shaft, not the disintegrator tool.

BEARING HOUSING AND TRIPLE MECHANICAL SEAL DESIGN

Vaughan S-Series submersible chopper pumps are uniquely different from other types of submersible sewage pumps because they use a bearing housing, with thrust bearings and extra mechanical seal (actually a third mechanical seal) located below the submersible motor. These additional components provide strength and rigidity to the submersible pump shaft as well as an additional degree of protection to the motor as described below. The typical submersible motor uses two single spring, rubber bellows mechanical seals with carbon and ceramic faces. Vaughan provides a third, high quality mechanical seal with silicon carbide faces. The seal is located immediately above the pump impeller on the pump shaft and isolates and protects not only the submersible motor above it, but also the oil-bath ball bearing system in the lower housing. The best indication of any problems with the mechanical seal system is a loss of oil from the oil reservoir (located above pit level), since the pump impeller pumpout vanes are designed to pull oil out of the bearing housing if a seal failure occurs.

AUTO OIL MONITOR SYSTEM

Vaughan Co. uses an automatic oil monitor system to monitor oil level in the clear reservoir located above pit level and to give immediate indication of a problem if oil level drops. Oil is monitored by a reed switch float in a clear reservoir. Connection to this oil switch is made through a watertight Woodhead connector or hard wired from the NPT cap at the top of the reservoir. Since the oil switch has only a 30 watt capacity, shutdown of pump motor (i.e., interruption of motor starter operation) is accomplished with a standard 110 volt control relay and base, which Vaughan supplies with the pump. If the pump is to be located in a hazardous environment, an intrinsically safe relay can be supplied. This relay eliminates any chance of having a spark in the reed switch. A schematic showing an example of motor controls system for the auto oil monitor system with a standard relay is included in this manual.

NOTE: If you have chosen to operate your pump without the oil monitor system (not recommended) you will need to pull your pump to check oil level. Vaughan recommends that you do this quarterly.

GUIDERAIL SYSTEM

Vaughan submersible chopper pumps can be supplied with a simple stand or with a guiderail system. The guiderail system allows the pump to be withdrawn from the pit without the need for anyone to enter the pit. When mounted on the guiderail elbow or spool the pump is supported completely by the pump casing discharge flange and adapter bracket. If the pump is to be mounted in a hazardous environment, you need to insure a non-sparking aluminum bronze adapter bracket is used for the pump.

SUBMERSIBLE RECIRCULATION NOZZLE ASSEMBLY (OPTIONAL)

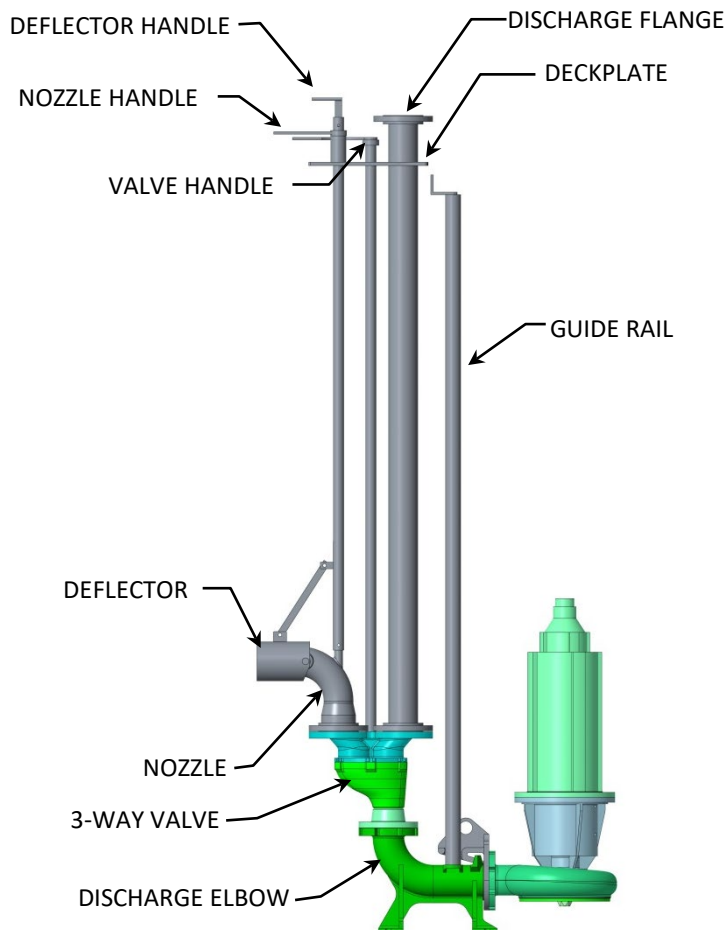

The Vaughan recirculation nozzle assembly consists of a 3-port valve with a recirculation nozzle mounted on the submersible pump discharge elbow and a deckplate to mount the handles for changing valve position and aiming the recirculation nozzle from above. See the illustration in Figure B.

The Vaughan recirculation nozzle assembly is specifically designed to mix the contents of a sump or scum pit by directing a stream of liquid into the sump or pit. This stream can be directed in various directions by adjusting the nozzle(s) up or down and left or right using the nozzle deflector control handle and the nozzle control handle respectively. This recirculation system allows the user to direct pump discharge back to the sump to mix liquid and debris in the pit to homogenize fluid prior to pumpout. Material is chopped up by the pump so that particle size is reduced and downstream plugging problems are eliminated. Recirculation mixing is particularly helpful in pits where material either settles or else floats on the surface, such as sewage scum pits.

RECIRCULATION NOZZLE MAJOR COMPONENTS

NOZZLE

The Nozzle is located on a swivel joint to provide rotation in the horizontal plane. The nozzle handle is located above the deckplate and is used to steer the nozzle to the right or left. A sprocket and dog type locking mechanism is provided to secure the nozzle in proper direction.

DEFLECTOR

A deflector is located on the nozzle to adjust flow direction in the vertical plane. The deflector handle control rod slides up and down within the nozzle handle. A pin with retaining clip is used to secure the deflector at the proper angle.

VALVE

Recirculating nozzle assemblies have 3-way valves, which allow the operator to direct the flow out the discharge pipe or recirculate the flow within the sump.

DECKPLATE

The deckplate is custom made to suit each installation.

B) PROPER APPLICATIONS FOR VAUGHAN CHOPPER PUMPS

Vaughan Chopper Pumps are used for pumping liquid slurries contaminated with debris which can be chopped and mixed into the slurry. The benefit of this approach is that a more homogenous slurry is pumped, making some slurries pumpable (which might otherwise not be pumpable) and eliminating downstream plugging in other equipment. Also, screens located upstream of the pump may often be eliminated, cutting labor costs. Vaughan pumps are routinely used to pump the following slurries:

1. Sewage and sewage sludge
2. Fish waste.
3. Vegetable waste.
4. Mill scale.
5. Lead oxide and plastics in battery plants.
6. Aluminum chips from machining operations
7. Oil sludges in oil refineries.
8. Wood chips and paper waste.
9. Animal manures (dairy cow, pigs, and chicken).
10. Feathers mixed with blood and water in poultry plants.
11. Animal fat in rendering and hide processing plants.
12. Plastic debris.
13. Coal slurry

System design is very important in making any pump work successfully in pumping debris-laden slurries. There must be enough liquid so that material can be pumped. Also, liquid and material must be able to flow freely to the pump.

C) USES OF VAUGHAN PUMPS THAT MAY CAUSE TROUBLE

If the system is not designed correctly for proper handling of your material, or if the pump is incorrectly chosen for your system, the pump may not work to your satisfaction or the pump may experience early failures of seals or bearings. The following problems can be experienced:

1. When pumps vibrate, they are damaged.
2. A pump must be operated in the solid line areas of its pump performance curve. Operation in the dashed lines indicates vibration areas.
3. Operating a pump against very low backpressure damages pumps.
4. Operating a pump against too much backpressure damages pumps.
5. Chopper pump impellers with the largest number of blades are the most efficient, but they also provide the poorest solids handling. Added impeller blades block the inlet and cause increased binding on fiber during chopping. When pumping sewage and similar slurries, choose impellers with the *least* number of blades
6. When pumping materials that float or settle in a pit, agitation and chopping with the pump are required before pit pumpout.
7. You cannot pump slurry that is too hot from an open pit. 65 deg C (149 deg F) is a reasonable upper limit for non-hazardous pits.
8. You must have a reliable electrical power supply for a pump to work properly. If you have too much voltage drop because of an undersized cable or transformer, the motor will not be able to provide full power to the pump and it will stall during chopping of debris.

D) EXPECTED BENEFITS OF VAUGHAN PUMPS

Most customers who install a Vaughan pump see several advantages:

1. Minimal pump attention is required.
2. Chances of pump plugging or binding on tough solid or fibers are minimized.
3. Minimal plugging problems downstream, because the material is preconditioned.
4. Elimination of ancillary grinders or comminutors upstream of the pump.
5. Long and reliable life of the Vaughan pump.

SECTION 3: INSTALLATION INSTRUCTIONS

A. RECEIPT INSPECTION

Prior to shipment Vaughan pumps are carefully crated and inspected to ensure arrival at your plant in good condition. On receiving your pump, examine it carefully to assure that no damaged or broken parts have resulted from mishandling during shipping. Look for signs that the pump has been dropped, such as missing paint, dented flanges, cracked housings, or leaking oil. Turn the pump shaft by hand and verify that it turns over smoothly. If the shaft binds, look for debris between impeller and cutter bar. Otherwise, shaft binding could indicate damage. If damage has occurred, report to your carrier immediately, and consult your local Vaughan representative or call Vaughan Co. for advice.

B. STORAGE CONSIDERATIONS

If equipment is to be stored for longer than two weeks, take the following action:

1. Coat exposed steel with a light layer of grease or protective spray-on lubricant to protect the equipment from corrosion.
2. Rotate the pump shaft 1-1/4 turn once each week to keep the bearings from sitting in one position for extended periods of time.
3. Avoid storing rotating equipment near other vibrating equipment. The vibrations can damage the bearings and result in premature failure once the equipment is started up.
4. Store rotating equipment in a clean, dry, heated area away from areas where it could be damaged from impact, smoke, dirt, vibration, corrosive fumes or liquids, or from condensation inside the motor or pump. It is helpful to cover equipment with plastic.
5. The bearing housing located below the submersible pump motor is about 85% oil-filled. (An air bubble needs to be kept in this housing to avoid ruining the seal from high pressure if outside temperature increases during shipping or storage.) These housings should be kept 85% filled with ISO 46 hydraulic oil during storage to be sure the bearings are kept covered to avoid corrosion.

C. MOUNTING THE PUMP AND GUIDERAIL SYSTEM IN YOUR PIT

The Vaughan submersible pump is heavy and will require a crane to lift it into position over your pit. Lifting the pump by the bail over the motor is the only recommended method for lifting.

⚠ WARNING

Lifting provisions included with Vaughan pumps are rated for overhead lifting; however, do not allow people under Vaughan equipment during hoisting operations. Lift pump and motor with an adequately sized hoist, crane, or forklift. Consult the Vaughan Co. shipping department for weight of your equipment if you are in doubt.

If the pump is to be mounted on a guiderail system, the base elbow will have to be bolted to the floor, and the guiderail upper bracket will have to be bolted either to your access cover frame or to some other structural member with stainless steel anchors. Expansion-type, cast-in place J-bolts, bolts mounted in sleeves, and epoxy anchoring systems are all acceptable anchoring means. The pump and elbow should be mounted at least 12" away from the nearest vertical wall in the pit. *Please note that before startup, the pump should be located out of the pit where correct pump rotation may be verified and the lower bearing housing can be completely filled with oil.*

The chart in Figure D will provide you with quantity, size, and location of anchor bolts for the base elbow or spool supplied with your pump.

If your pump was ordered with a recirculation nozzle assembly orient the deckplate of the nozzle assembly so as to make best use of the available nozzle rotation. In round pits, it is best if the assembly can be positioned so the nozzle can discharge parallel to the pit wall in both directions so that either clock-wise or counter-clock-wise rotation can be established. In rectangular pits, position the unit near one corner with the nozzle capable of being aimed at the three remaining corners.

Figure C shows a typical submersible pump and guide rail system mounted in a pit. Normally the customer or the contractor will supply Schedule 40 galvanized or stainless steel pipe for the actual guide rails. All other components in the guide rail system are available from Vaughan. When lifting a submersible pump on the guide rail system, use caution to avoid binding of the discharge bracket on the guiderails. Adjusting the angle on which the lifting cable pulls up on the lifting bail can relieve a great deal of the binding that might otherwise occur.

After startup, when lowering the pump into a pit on a guiderail system, it may be helpful to turn the pump on while the pump is mating to the elbow so that any debris may be flushed away from the mating surfaces, thus minimizing chances for leakage later. **(Never do this with 3600 RPM pumps.)**

Vaughan submersible pumps use a metal-to-metal connection between pump and discharge elbow for minimum mating problems over the life of the equipment.

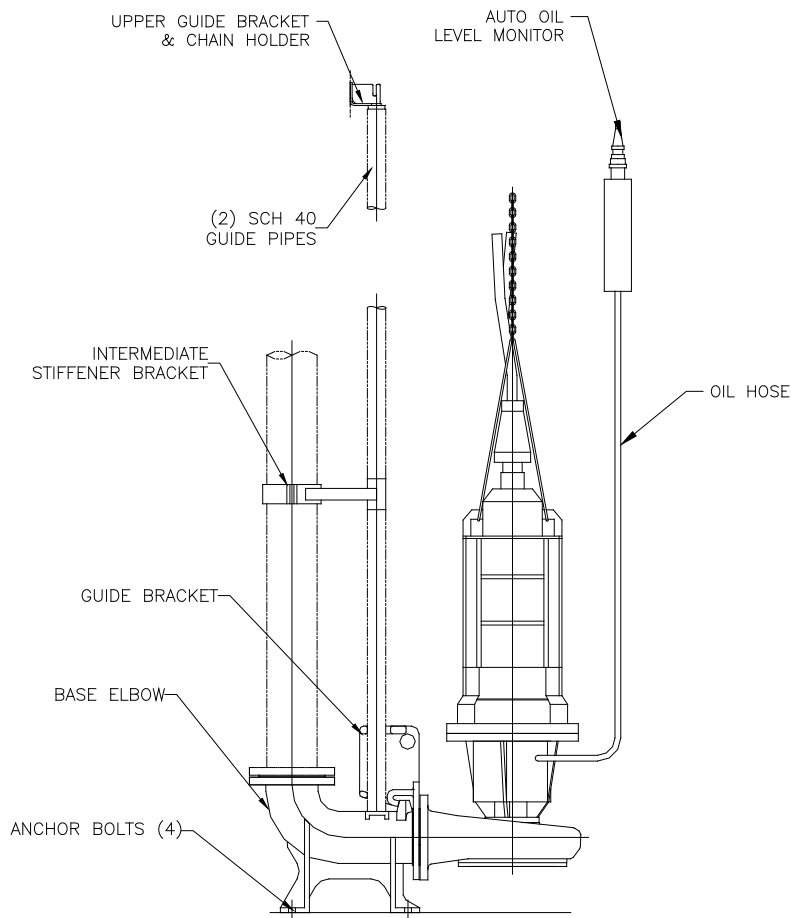

Figure C

The exact details of your pump and guiderail system (i.e. parts breakdown, outline dimensions, and weight) are available from Vaughan Co.

Figure D

VAUGHAN SUBMERSIBLE PUMP BASE ELBOW
ANCHOR BOLT INFORMATION

3"–10" BASE ELBOWS

6"&12"–20" BASE SPOOLS

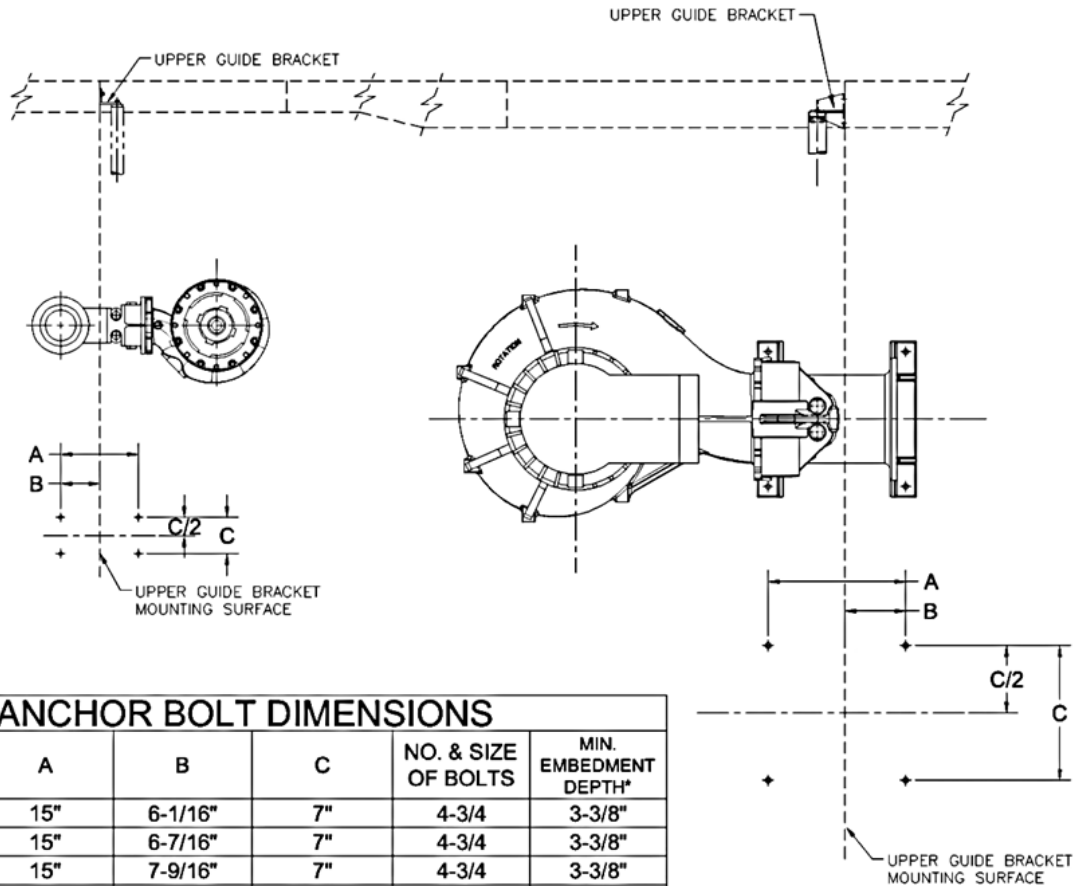

ANCHOR BOLT DIMENSIONS

BASE SIZE	A	B	C	NO. & SIZE OF BOLTS	MIN. EMBEDMENT DEPTH*
3" Elbow	15"	6-1/16"	7"	4-3/4	3-3/8"
4" Elbow	15"	6-7/16"	7"	4-3/4	3-3/8"
6" Elbow	15"	7-9/16"	7"	4-3/4	3-3/8"
6" Spool	11-13/16"	-1-5/8"	9-3/16"	4-3/4	3-3/8"
8" Elbow	11"	3-7/16"	9-1/2"	4-3/4	3-3/8"
10" Elbow	19-11/16"	12-3/16"	9-1/2"	4-3/4	3-3/8"
12" Spool	14-11/16"	2-9/16"	24-1/2"	4-1	4-1/2"
20" Spool	26"	11-3/16"	26"	4-1	4-1/2"

*MINIMUM EMBEDMENT DEPTH IS FOR SUP-R-STUD ANCHOR BOLTS IN 2000PSI OR GREATER STRENGTH CONCRETE

MOUNTING THE NOZZLE ASSEMBLY IN YOUR PIT:

The Vaughan recirculation nozzle assembly is heavy and will require a crane to lift it into position over your pit. Wrapping appropriately rated lifting straps around the handles below the deckplate is the recommended method for lifting.

The outline dimension drawing prepared for your particular nozzle assembly shows anchor bolt locations, piping connection location, weight, and nozzle orientation.

Orient the deckplate of the nozzle assembly so as to make best use of the available nozzle rotation. In round pits, it is best if the assembly can be positioned so the nozzle can discharge parallel to the pit wall in both directions so that either clock-wise or counter-clock-wise rotation can be established. In rectangular pits, position the unit near one corner with the nozzle capable of being aimed at the three remaining corners.

The exact details of your nozzle assembly, (i.e., parts breakdown, outline dimensions, and weight) are available from Vaughan Co. The illustration in this manual shows a typical arrangement.

INSTALLATION OF VALVE AND NOZZLE HANDLE ASSEMBLY

- Refer to outline drawing dimension for the location of the base elbow and valve body assembly. Mount the assembly to the bottom of the pit.
- Cut hole in slab per outline dimension drawing for handle extensions.
- Position the deckplate such that the handles are vertically directly over the valve body nozzle mating parts. Preferably, this is done with the aid of a plumb bob.
- If your handles are split couple them and tighten the set screws in the coupling with thread locker. There are also two 3/8" bolts that need to be installed to connect the deflector linkage.
- Loosen the set collars under the deckplate so that the handles can be adjusted and pushed down onto their mating components (valve and recirculation nozzle).
- Secure the deckplate to the floor slab.
- Slide set collar up against bottom of deckplate.
- Tighten set collar set screws to 130 inch pounds (11 foot pounds) with thread locker.

PIPING

As a general rule in piping layout, avoid frictional losses by minimizing fittings and abrupt changes in direction and by choosing piping size carefully. Remember, that when pumping sludges that this material has significantly higher friction losses than water; so larger diameter piping is often required. If you are going uphill or into a force main, or if there is more than one pump pumping into a common header, a check valve and isolation valve will be required on the discharge of the pump. *It is strongly recommended that you provide a pressure tap in the valve box or in the piping just above or out of the pit so that you can measure the actual operating conditions of the pump during startup. Also, if you are ever required to do any troubleshooting, this fitting will be required.* For pumping suspended solids, maintain at least 3-5 fps velocity in horizontal runs, and 8-10 fps in vertical runs. Otherwise, material can settle and plug the discharge line, particularly at elbows.

NOTICE

Be sure that all piping connections are tightened and properly supported before operation of this pump.

D. CONTROLS

If your installation is considered a hazardous location, be sure an electrician experienced in hazardous environment wiring and controls is involved with your installation and that the control relay used for the Auto Oil Monitor System is an "intrinsically safe" relay. See the Auto Oil Monitor System Installation on page 12 of this manual.

Vaughan Submersible Chopper Pumps, because they cut and condition the material they pump, require positive motor protection with correctly sized breakers, starters, and overload protection. A Chopper Pump can jam and stall on material too tough to chop, such as steel rebar. Therefore, carefully chosen overload protection for your submersible motor is critical to avoid motor burnout. Note that nuisance tripping during chopping can occur if you do not have an adequately sized circuit breaker. The circuit breaker should never open during chopping, only during a short circuit. High current trip settings for Starters and VFD's should be set at 110% of motor nameplate full load current to prevent the current spikes from tripping out those devices while chopping.

Also, the submersible motors have two protective devices, the seal failure moisture probe and the thermostatic switches. Both of these devices must be incorporated into the controls along with the Vaughan auto oil level monitor. The controls schematics presented in this manual show these items wired into the system. Also, please see the motor Installation and Operating Manual for more details on these devices.

Most submersible motors are suitable for use with VFD's, or can be special ordered with "inverter duty" nameplates. Most motors (except for 2 pole/3600 rpm motors) are suitable for running at increased speeds to 150% of base speed or more, provided they stay within their current rating.

Selecting a motor with a base speed at the upper end of your operating range and slowing it down using a VFD to hit the low range results in lowest available torque and may not be recommended.

Note, when slowing a motor down below nameplate speed with a VFD it is very important to remember that available horsepower drops in direct proportion to speed reduction, so a 100 HP motor running at 30 Hz can only make 50 HP max at 30 Hz.

Selecting a motor with a base speed at the lower end of your operating range and speeding it up using a VFD to hit the high range results in the highest available torque and is generally preferred for chopper pump applications. *When speeding a motor up above nameplate speed, available horsepower = nameplate horsepower.*

When driving chopper pump motors with a VFD, it is important that Constant Torque type VFD's be specified. Constant torque VFD's allow for maximum chopping torque at all speeds. (Variable Torque units have reduced torque and horsepower at reduced speeds) Minimum allowable VFD speed is dependent on system curve, and is the speed required to maintain minimum allowable flow per our published curves. Consult Vaughan Co. for assistance if needed.

Severe duty applications like septage receiving, screenings, beef processing, or any application with an external cutter often require oversizing the motor to get sufficient torque. Oversizing the motor has the added benefit of increasing rotational inertia to help carry the impeller through each chop.

E. SUBMERSIBLE MOTOR

Read the submersible motor Application, Installation and Operation Manual before operating this equipment.

Please note that the submersible motor is designed to be cooled by the liquid in the pit. It can operate only 15 minutes in air before overheating and automatic opening of the internal thermostatic switches. For proper cooling and operation of this motor, it must be covered by liquid, or if it's uncovered, it must not operate for more than 15 minutes in air. Also, this motor is designed for explosion proof use in liquids at temperatures up to 104°F (40°C). In non-hazardous environments it can operate up to 149°F (65°C). This motor is not rated for use in liquid temperatures which exceed these limits.

Also, the biggest cause of problems with submersible motors is electrical cable damage or damage to the cable cap assembly. Do not stretch the cable! And never lift the pump by the electrical cable! Otherwise, it will be damaged. Damage shows up as moisture probe or thermostatic switch failures (damage to the smaller of the two wires) or can result in a short of the main power cables.

⚠ WARNING

The submersible motors used on these pumps meet explosion proof requirements for hazardous environments. However, the guiderail system or oil monitor system may not meet the requirements for installation in a hazardous environment unless specifically ordered for this purpose. Introducing equipment not rated for a hazardous environment as defined by the National Electric Code can cause a dangerous explosion.

SAMPLE SCHEMATIC FOR SUBMERSIBLE PUMP NON EXPLOSION PROOF

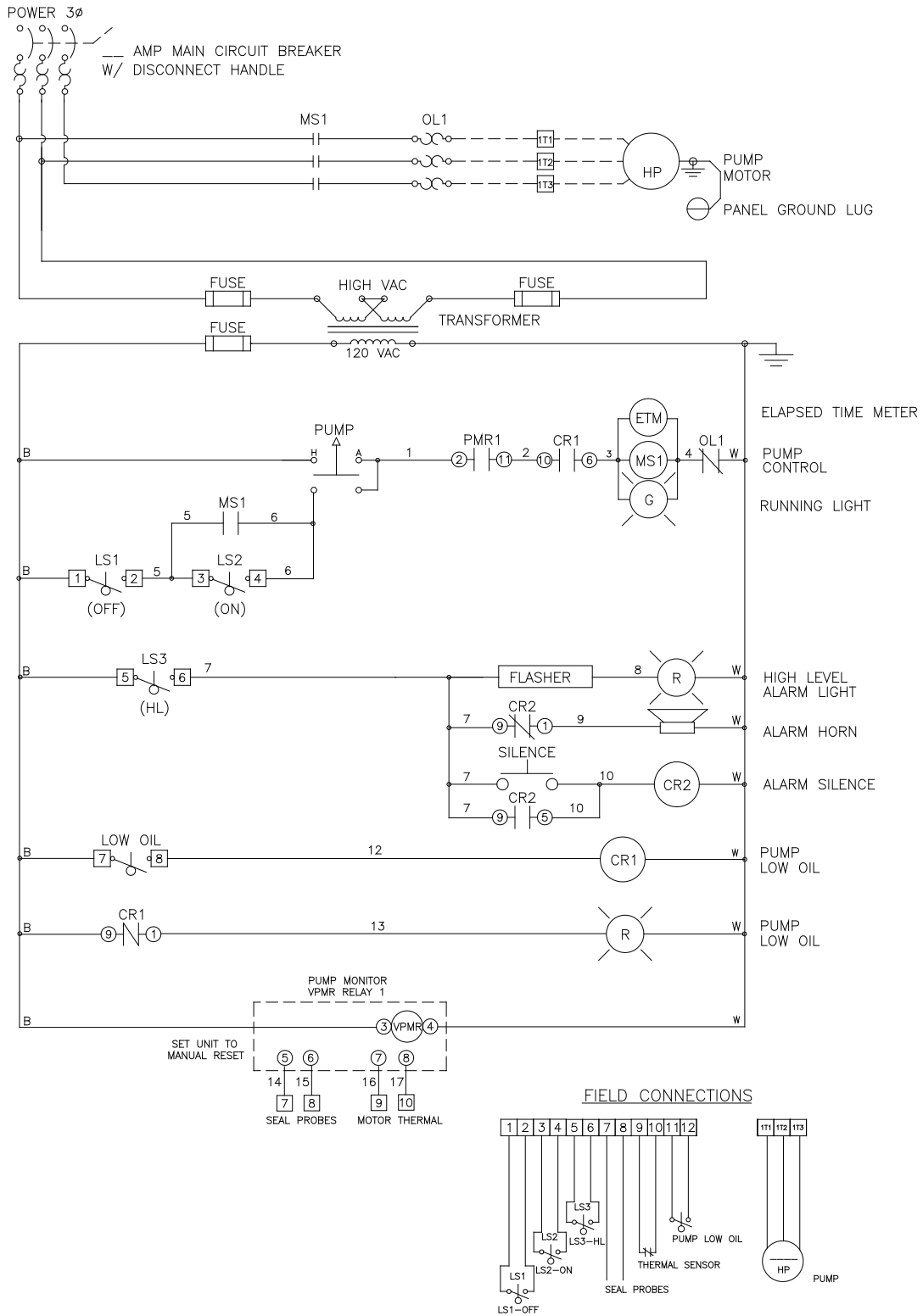

AUTO OIL LEVEL MONITOR

The Vaughan Automatic Oil Level Monitor (OLM) System constantly monitors oil level in the bearing housing below the submersible motor. The auto OLM system is totally independent of the protective functions built into the submersible motor. The auto OLM system is designed to shut the pump down whenever oil level drops below a preset level. If desired, an alarm can be sounded on low oil level to alert the operators of a problem in the mechanical seal system.

The system is composed of a small liquid level switch mounted in the oil reservoir, and a control relay mounted in the control panel with the motor controls. Vaughan Co. supplies both the pump-mounted oil monitor/oil reservoir, and the control relay with 8-pin base for mounting in the customer's panel. The Auto OLM system allows the pump to operate normally as long as the oil is at an acceptable level in the reservoir. However, on loss of oil, usually due to seal damage, the oil level drops, the oil switch then opens, the control relay in the panel becomes de-energized, and the control relay contacts wired in series with the pump motor starter open up and interrupt voltage to the starter. This sequence of events shuts down the pump. The schematics presented in this manual illustrate how Vaughan Co. intends this system to work.

NOTICE

Be sure the oil reservoir is located above flood level. If water is allowed to enter the oil reservoir, it will end up contaminating the pump and cause premature bearing and seal failure.

Because the bearing housing in the pump is completely full of oil, you will be able to see a "thermometer effect" in the oil reservoir. That is, oil height in the clear reservoir will move up as oil heats up, and will contract and fall in the reservoir during cool down. This is normal. If you overfill the reservoir at startup, you may see some overflow of oil out the vent hole of the cap during heat up. But as long as the oil switch does not shut the pump down or keep the pump from starting up after cool down, you do not have a seal leak. There is a decal on the side of the reservoir indicating that at startup with the system cold, oil should be about half way up in the reservoir.

Figure E

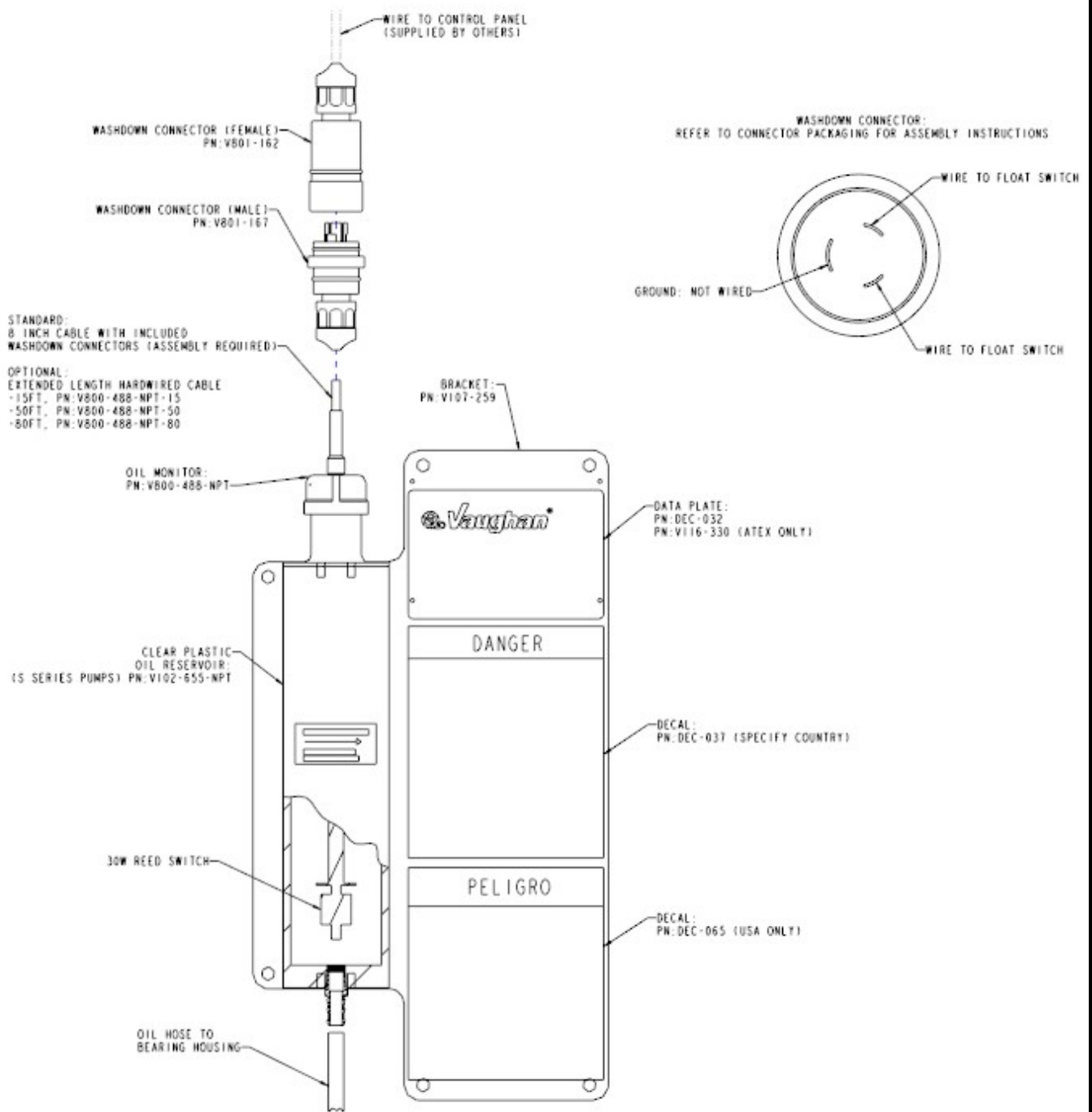

SECTION 4: STARTUP INSTRUCTIONS

Review safety information in Section 1 of this manual before proceeding.

The submersible chopper pump cannot be properly started unless the pump is out of the pit. With the pump out of the pit, lying horizontally, take the following action:

⚠ CAUTION

When performing start up on new or rebuilt pumps, there is a risk of foreign objects or broken pump parts being thrown from the pump suction or discharge opening as a projectile. Discharge flange should be blocked, and suction opening should be covered with a heavy screen to protect personnel during the rotation check

1. Perform the rotation check. When checking pump rotation first restrain the pump, then at the control panel, hit the "ON" button, then the "OFF" button as fast as possible to merely "jog" the motor. If the impeller turns counterclockwise (as seen from the intake), then you are ready to start the pump. If the impeller turns clockwise, (wrong direction), then open the circuit breakers to the motor panel following your plant's lockout/tagout procedures for locking and tagging out breakers, and then reverse any two leads to the motor starter in the control panel. Then close the breakers to the panel, and recheck the motor direction to be sure it's correct.

⚠ CAUTION

Restrain the pump during the rotation check to prevent pump from rolling when energized.

⚠ CAUTION

If the pump is allowed to run backwards for any significant length of time, the pump can be damaged.

⚠ WARNING

Stay clear of pump suction while performing pump rotation check. Serious injury or loss of limb is possible if clothing or hands are caught by the impeller.

⚠ WARNING

Lockout power after performing rotation check. The following steps are to be performed with the power off and locked out.

2. Remove both ½" NPT pipe plugs from the bearing housing below the motor. Then using Teflon tape or sealant, install the oil reservoir hose in the upper hole (nearest to motor) as a vent. Fill through the other with ISO 46 hydraulic oil until the housing is completely full. (Having the fill hole elevated slightly above the motor flange will reduce the possibility of air pockets.) Install plug in the fill hole and plug the end of the oil hose. After the pump is installed onto the guiderail elbow, trim the hose to length, connect it to the oil reservoir, and zip tie it to the motor cables. Add oil through the reservoir to complete the filling operation.

If you have ordered your pump without the oil level monitor stand the pump up and fill through the top port until oil is level with the bottom of the port.

NOTICE

If the pump has no oil monitor the oil level should be checked monthly.

Vaughan Co. uses Chevron Rando HD-46 which is ISO 46 hydraulic oil. The following oils have the viscosity and rust inhibiting additives to make them excellent alternates for the Rando HD 46: Shell Turbo 46, Texaco Regal 46, Mobil DTE 46, and Exxon Teresstic 46. Most ISO 46 hydraulic oils and ISO 46 turbine oils should be compatible with Rando HD 46 supplied in our pumps.

3. Install the pump on the guiderail system. Solid mounting of the pump onto the guiderail elbow helps keep vibrations minimized during operation of the pump. Anything you can safely do to make sure the pump is firmly seated onto the elbow will be helpful.
4. Add oil through the reservoir to complete the filling operation.
5. Clean all construction debris from the wet well.

When steps 1 – 5 are complete the pump is ready for startup and may be energized.

The startup instructions are incorporated into the Startup and Certification Checklist. When the Startup and Certification Checklist is completed please send a copy of the completed checklist to: STARTUP@CHOPPERPUMPS.COM. We will verify that the pump and system are properly matched to protect your investment and our reputation.



DATE: _____

Project Name: _____ Location: _____

Pump S/N: _____ Equipment ID/Tag#: _____

Startup Performed By: _____

Customer Contact Info _____

Contractor Contact Info _____

Engineer Contact Info _____

PRE-STARTUP CHECKLIST

- Was rotating equipment stored in a clean, dry heated area away from areas where it could be damaged from impact, smoke, dirt vibration, corrosive fumes, or liquids, or from condensation inside the motor or pump?

Yes _____ No _____

- If no, are you aware of any damage the equipment may have sustained?

- Was the shaft rotated 1-1/4 turn once each week? Yes _____ No _____

- If no, how often was the shaft rotated?

- Was the exposed steel covered with a light layer of grease or Cosmoline to protect the equipment from corrosion?

Yes _____ No _____

- Was the bearing housing kept filled with ISO Grade 46 hydraulic oil (does not apply to SE Submersibles)?

N/A _____ Yes _____ No _____





DATE: _____

Project Name: _____ Location: _____

Pump S/N: _____ Equipment ID/Tag#: _____

Startup Performed By: _____

Customer Contact Info _____

Contractor Contact Info _____

Engineer Contact Info _____

**VAUGHAN "S" SERIES SUBMERSIBLE CHOPPER PUMP
STARTUP AND CERTIFICATION CHECKLIST**

Email completed form to: STARTUP@CHOPPERPUMPS.COM

- | | | |
|--------------------------------------------------------------------------------------------|-----------|----------|
| Pump Shaft turns freely by hand? | Yes _____ | No _____ |
| Pump is turning CCW as viewed from the pump end? | Yes _____ | No _____ |
| Is pump properly filled with Rando HD-46 oil (or equal)? | Yes _____ | No _____ |
| Is the oil level in the middle of the range of the oil reservoir? | Yes _____ | No _____ |
| Is Auto Oil Level monitor properly connected? | Yes _____ | No _____ |
| Moisture Sensor Relay connected and tested to ensure proper function? | Yes _____ | No _____ |
| All piping attached to pump is being independently supported? (not by the pump) | Yes _____ | No _____ |
| All piping joints are leaktight? | Yes _____ | No _____ |
| Flexible joint is attached to pump discharge? | Yes _____ | No _____ |
| If yes, is piping anchored between expansion joint and pump discharge, per H.I. Standards? | Yes _____ | No _____ |
| Are discharge valves open? | Yes _____ | No _____ |
| Does Inflow splash down into sump? | Yes _____ | No _____ |
| Has wet well been cleaned of all construction debris? | Yes _____ | No _____ |
| Recirculation nozzles turn freely? N/A _____ | Yes _____ | No _____ |
| Deflector moves freely up and down? N/A _____ | Yes _____ | No _____ |

ELECTRICAL DATA

Motor Mfr: _____ HP: _____ RPM: _____
 Nameplate Voltage: _____ Nameplate F.L. Amperage: _____
 Operating Voltage: L1 – L2: _____ L2 – L3: _____ L1 – L3: _____
 Operating Amperage: L1: _____ L2: _____ L3: _____

SYSTEM DATA

What type of material are you pumping? _____
 Temperature (°F) _____ Specific Gravity _____ %Solids _____



Pipe Size (inch): _____ Total equivalent length of pipe (feet) _____
 Elevation change from water level to discharge point (feet) _____
 Estimated Total Head (feet): _____ Design Flow (GPM): _____

PUMP OPERATING DATA

Pump Model: _____ Impeller Diameter: _____
 Discharge Pressure (psig): **Pump Off (psi):** _____ **Pump On (psi):** _____
 Dim "Z" (feet) _____ (distance from liquid level to pressure gauge)
 Observed Flow (GPM): _____
 Is pump running quietly? _____ Noisily? _____ Very Noisily? _____

NOTE: If pump is not running quietly, please contact us immediately for help. Severe vibration can damage the pump very quickly.

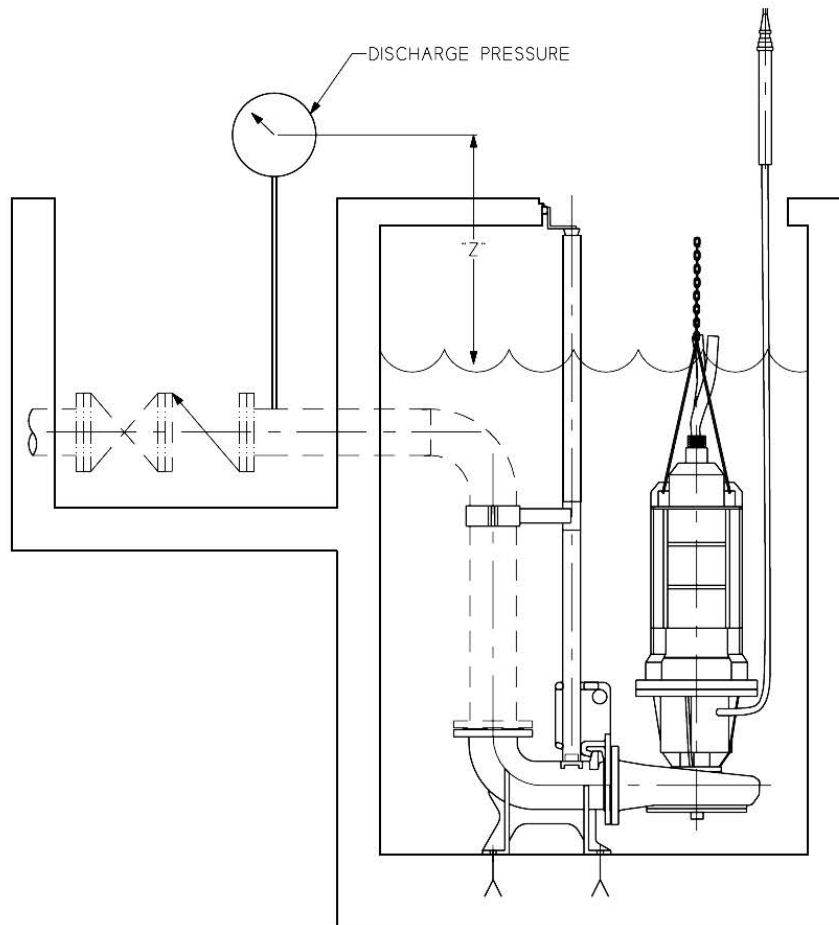

SECTION 5: NORMAL OPERATION

NOTICE

Pump speeds and operating conditions must fall within the acceptable limits of the performance curve of the pump.

NOISE:

The Vaughan pumps which operate at either 1750 RPM or 1170 RPM are normally quiet running, and the major source of noise is the electric motor. Higher head pumps operating at 3510 RPM, however, will be noisier due to the nature of the pump design. Typically, noise level will be around 90-93 dbA in this pump. (However, mechanical vibrations should be minimal.) Also, there are times, particularly at startup, when the pit may be in bad condition, and an otherwise quiet running pump will be fairly noisy, due to the large amount of chopping and conditioning work that the pump must do. In time, the pump noise should dissipate as the majority of the difficult material is broken up and homogenized.

VIBRATION:

Vibration, like noise, should be minimal in the pump unless the pump is doing heavy chopping. If a particularly tough rag, or nylon pantyhose gets caught in the pump, temporary dynamic imbalance and some flow blockage will occur until the rag is chopped up and cleared. These conditions will create vibration that is undesirable. But this condition is generally only temporary, and the chopping action of the pump normally clears the obstruction with time.

Please note that every effort has been made at the factory to ensure that this pump operates smoothly and without vibration. For example, all impellers are dynamically balanced after machining and heat treat to the ISO 1940/1 G6.3 balance standard. The pump shaft is very tightly held by the bearings so that there is virtually no shaft movement.

The most important action that you can take to eliminate vibration during operation is to make sure that you have a firm, solid, massive foundation to bolt the pump to during installation. Also, during repair, following the Vaughan Overhaul procedures and using Vaughan parts will give you the best chance of keeping your pump operating as smoothly as possible over time. And finally, pumping liquid below 40°C or 65°C (see page 7) and operating the pump within the allowable head/flow (solid line) portions of the performance curve will make sure that the pump does not cavitate and vibrate.

If after startup the pump is vibrating, it may be helpful to lift the pump up and reseal it onto the elbow several times. Sometimes resealing the pump onto the elbow with the pump running is helpful. (Only do this with 1750 or 1170 RPM pumps, **never with a 3510 RPM pump.**)

MOTOR OVERLOADS:

A motor overload is not part of normal operation, but can happen more often in a chopper pump than in other types of "non-clog" pumps because of unpredictable chopping demands. If you find that the motor has tripped out on overload, have an electrician check operating amps when you restart the motor. Make sure that the motor is not pulling more than max allowable full load amps. **Note especially that repeatedly resetting the motor overload devices and restarting the motor when it repeatedly trips out again is a guaranteed way to burn out the motor!** Please pull the pump up out of the pit and see if something not choppable is stuck in the pump before you ruin this expensive motor.

OIL USAGE:

All seals must leak some small amount of oil out or water in to provide cooling and lubrication to the seal faces. Normally, with the seal in good condition, this will be a very small amount, perhaps one or two ounces per year. Note also the "thermometer effect" discussed in the Installation section of this manual.) If the pump uses large amounts of oil or if the oil is contaminated, mechanical seal damage may have occurred.

(Verify that the oil reservoir has not been flooded from the top.) If the seal is leaking, the unit should be repaired immediately to head off more expensive repairs. Call Vaughan Co. immediately for advice.

Vaughan Co. can send out a bearing and seal system sub-assembly overnight, if necessary, to support your operations. Should repair be necessary, please carefully follow the instructions of the Overhaul Manual that was supplied with your pump. Because the Vaughan pump has a unique bearing and seal design, it is extremely difficult to repair the pump properly if you do not have detailed directions to follow.

In unusual circumstances, the oil in the reservoir will become very slightly “milky” in appearance. Generally, this happens because condensation occurs inside the reservoir as temperature and weather changes. If the oil is only slightly milky, it will not present any problems for the pump. Obviously, if too much water gets into the oil, the oil (or the seal) must be changed.

SECTION 6 SHUTDOWN INSTRUCTIONS

MANUAL SHUTDOWN:

In the manual mode of operation, a Vaughan pump is shut down by hitting the “OFF” button or turning the auto/man/off switch to the “OFF” position on the front panel of your control panel. If any repair or maintenance work is to be done on the pump, be sure to follow all the warnings at the beginning of this manual.

AUTOMATIC SHUTDOWN:

Automatic operation normally shuts the pump down for you, usually on low pit level. If the pump does not shutdown when the pit is pumped out, the pump may be shutdown manually, but you will want to troubleshoot your level control system to find out why the auto operation is not working properly.

If you are going to do any maintenance, adjustment or inspection on this pump or motor, be sure to follow all warnings in this manual, and your plant’s safety procedures. Be certain to turn off electrical power by opening and locking out the main panel breaker to isolate the pump. Since in the automatic mode, the pump could start without warning if not isolated.

⚠ WARNING

Lockout main panel breaker to prevent unintentional starting when working on this equipment

EMERGENCY SHUTDOWN:

In any kind of emergency when the pump needs to be shutdown, hit the manual “OFF” switch or pushbutton on the front of the pump control panel. If any work has to be done on the pump or motor, open the main breaker on the pump control panel so that the pump cannot automatically restart when personnel are near the pump or motor.

SECTION 7: MAINTENANCE

ROUTINE MAINTENANCE

MONTHLY:

1. Check amperage draw to the pump motor and compare to that measured at startup. Make sure that power draw does not exceed allowable amperage to the motor at full load.
2. Visually check the condition of the oil in the clear reservoir to make sure it is not contaminated or milky.
3. If your pump is equipped with recirculation system check operation of the nozzle, the deflector, and the 3-way valve. You may want to take this opportunity to reverse or otherwise adjust the mixing pattern.

ANNUALLY:

Remove pump from the pit and inspect for wear or damaged parts. Check impeller clearance from cutter bar. It should be no greater than 0.025” maximum. Follow the procedure below applicable to your pump model to adjust impeller to cutter bar clearance or replace impeller and cutter bar as required. Check for smooth shaft rotation by rotating the pump shaft by hand.

Be especially alert to rough spots on the bearings. Make sure there is no axial play in the pump shaft and that no oil is leaking across the seal faces into the pump bowl. Inspect pump casing and adapter bracket for wear and replace as necessary. Check for loose, corroded or worn hardware and tighten or replace as necessary.

⚠ WARNING

The impeller and cutter bar are sharp. Wear gloves to protect your hands from cuts and possible serious infection.

- 1) Remove the cutter bar perimeter bolts and pry the cutter bar off with a pry bar. It is also possible to pry around the perimeter with screw drivers to remove the cutter bar.

⚠ CAUTION

Depending on pump size the cutter bar can be very heavy. To avoid physical injury and/or equipment damage make sure not to drop the cutter bar when it comes loose.

- 2) Remove the old shims, making sure to clean both the cutter bar and casing surfaces of any old material that may be stuck on them. Once the surfaces are clean install two cutter bar alignment pins. Place 4-6 shims on the alignment pins and install the cutter bar.
- 3) When tightening the cutter bar bolts use a cross pattern and tighten them in stages to get an even compression of the shims. Treat the cutter bar bolts with Loctite 242 and torque to 45 ft./lbs. for 3/8" bolts, and 95 ft./lbs. for 1/2" bolts.
- 4) Check the cutter bar/impeller gap. The acceptable range is .015"-.025". If the gap is not within the acceptable range repeat the procedure, adding or removing shims until there is no interference and the gap is acceptable. Make sure the cutter nut is not contacting the ends of the cutter bar fingers.

If your pump is a back pullout design S3P, S3V, S4V, S8K, or S8L follow these steps to adjust the cutter bar/impeller gap.

- 1) Loosen and back off each of the clamp bolts on the casing backplate, ensuring that the adjusting sleeves do not move with the bolts. Choose three approximately equally spaced sleeves that you will use to perform the adjustments. Back all the other adjusting sleeves away from the casing by turning them counter clockwise.

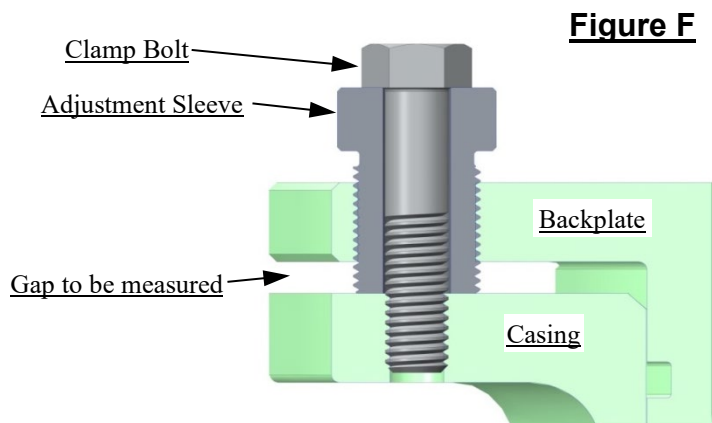

- 2) Before dialing in the impeller-to-cutter bar clearance, it's important to verify that the impeller and cutter bar are parallel to each other. You can check this by using a piece of key stock that is larger than the gap currently present between the backplate and casing flanges. This will generally be somewhere around 3/16" to 1/4". Use the key stock to ensure that the gap is exactly equal at each of your three chosen adjustment sleeves with the clamp bolts tight. Before you begin to make adjustments, witness mark the three adjustment sleeves to help you confirm all of the sleeves have been rotated evenly, and the impeller and cutter bar stay parallel to each other.
- 3) Decrease the impeller-to-cutter bar gap by rotating each of the three adjustment sleeves counter clockwise by an equal amount, tightening the clamp bolts, and then checking for contact by rotating the shaft. You may need to repeat this step a couple of times if the pump has some wear on it. Each flat of rotation of the adjustment sleeve hex nut is worth .010" to .012" of cutter movement. Close up the gap until light contact occurs between impeller and cutter bar.

- 4) When you have the cutters lightly touching, unclamp the adjustment sleeves once again, carefully rotate them two flats clockwise, and retighten the clamp bolts. This will yield an impeller-to-cutter bar clearance of about .020" to .024". This is an acceptable number for all models.
- 5) Snug the unused adjustment sleeves against the casing. Make sure that the adjustment sleeves bottom on the casing, and are not tightening on anything that will crush when the clamp bolts are tightened. Lock all the adjusters down with the clamping bolts, and tighten the bolts that you loosened on the baseplate. After all bolts have been securely tightened, check for smooth shaft rotation by rotating the pump shaft again by hand. If the proper clearance cannot be achieved, or if other damage requires it, the impeller and cutter bar may need to be replaced. If this becomes necessary, refer to the overhaul instructions for the proper procedures for this operation.

CORRECTIVE MAINTENANCE:

Because overhaul of a Vaughan submersible pump is a major undertaking, the Overhaul Instruction is a separate procedure. Please do not try to overhaul or repair the pump without this important procedure and without the exploded assembly parts breakdown. The overhaul manual was sent to you by mail when your order for the pump was placed at the factory. If you do not have a copy of this manual, please call Vaughan Co. Engineering; we will make sure you get proper instructions overnight.

SECTION 8: TROUBLESHOOTING

The following table deals with pump and system problems but not with motor problems. The warranty for the submersible motor is covered by the motor manufacturer, but before contacting the motor manufacturer; please contact Vaughan Co. for advice!

Attached to this section is a troubleshooting chart that will help you get some idea of what symptoms could cause what problems. If you would like help, please call Vaughan Co. Engineering for troubleshooting help. We'll be glad to offer assistance.

Note if your pump is equipped with a recirculation nozzle mid-stroke operation can cause debris to collect on the valve disk but simply cycling the valve should dislodge the debris.

		Short Life of Pumping Parts	Low Discharge Pressure	Oil Loss or Contamination	Excessive Power Required	Abnormally High Vibration	Short Bearing or Seal Life	Pump Binding or Plugging	High Bearing Temp	Low Flow
SUCTION PROBLEMS	Insufficient NPSH		✓			✓	✓			✓
	Gas Binding of Pump (air trapped in eye of impeller)		✓			✓	✓			✓
	Vortexing in Pit at Inlet					✓				✓
	Intake Openings Blocked		✓			✓				✓
SYSTEM PROBLEMS	Pump Speed Too High/Impeller too Large	✓			✓	✓	✓			
	Pump Speed Too Low/Impeller too Small		✓			✓	✓			✓
	Fluid Excessively Hot	✓	✓			✓	✓			✓
	Pump Too Near Wall or Floor					✓	✓	✓		
	Pump Rotation Incorrect	✓	✓		✓	✓	✓	✓		✓
	System Head Too High					✓	✓			✓
	System Head Too Low	✓	✓		✓	✓	✓			
	Excessive Strain or Weight on Pump Flange					✓	✓			
	Pumped Fluid Abrasive or Corrosive	✓	✓					✓		✓
	Specific Gravity Higher than Expected				✓					✓
	Viscosity Higher than Expected				✓					✓
	Operation at Low Capacity					✓	✓			
	Improper Parallel Operation of Pumps	✓				✓	✓			✓
	Improper Series Operation of Pumps	✓			✓	✓	✓			
ELECTRIC PROBLEM	Loss of Phase				✓			✓		
	Low Voltage				✓			✓		
	Phase-to-Ground Leakage				✓					
MECHANICAL PROBLEM	Pump Discharge Blocked					✓				✓
	Foundation not Rigid					✓	✓			
	Disintegrator Tool Wrapped with Rags					✓	✓			✓
	Worn Bearings				✓	✓			✓	
	Flooding of Oil Reservoir			✓						
	Overfilling of Oil Reservoir / Thermometer Effect			✓						
	Mechanical Seal Failure			✓						
	Bent Shaft					✓	✓			
	Cutter Bar or Impeller Worn				✓			✓		
	Impeller Damaged or Loose on Shaft	✓	✓		✓	✓		✓		✓
	Shaft Running Off Center					✓	✓			
	Lack of Lubrication				✓	✓	✓		✓	
	Improper Repair/Installation of Bearings			✓		✓	✓			
	Dirt in Bearings					✓	✓			
Impeller hitting internal cutter					✓					



VAUGHAN CO., INC. PRODUCT WARRANTY

Vaughan Company, Inc. (Vaughan Co.) warrants to the original purchaser/end user (Purchaser) all pumps and pump parts manufactured by Vaughan Co. to be free from defects in workmanship or material for a period of twelve (12) months from date of startup, not to exceed eighteen (18) months from the date of shipment from Vaughan Co. Startup data must be submitted to Vaughan Co. within 30 days of startup. If Purchaser fails to submit startup data within 30 days of startup, then Vaughan, in its sole discretion, may elect to void this warranty at any time. Purchaser must contact Vaughan Co. prior to commencing any repair attempts, or removing pump or parts from service. If Purchaser fails to contact Vaughan Co. prior to commencing any repair attempts or removing pumps or parts from service, then Vaughan, in its sole discretion, may elect to void this warranty at any time.

If during said warranty period, any pump or pump parts manufactured by Vaughan Co. prove to be defective in workmanship or material under normal use and service, and if such pump or pump parts are returned to Vaughan Co.'s factory at Montesano, WA, or to a Vaughan authorized Service Facility, as directed by Vaughan Co., transportation charges prepaid, and if the pump or pump parts are found to be defective in workmanship or material, they will be replaced or repaired by Vaughan Co. free of charge. Products repaired or replaced from the Vaughan Co. factory or a Vaughan authorized Service Facility under this warranty will be returned freight prepaid. Vaughan Co. shall not be responsible for the cost of pump or part removal and/or re-installation.

All warranty claims must be submitted in writing to Vaughan Co. not later than thirty (30) days after warranty breach occurrence. The original warranty length shall not be extended with respect to pumps or parts repaired or replaced by Vaughan Co. under this Warranty. This Warranty is voided as to pumps or parts repaired/replaced by other than Vaughan Co. or its duly authorized representatives.

Vaughan Co. shall not be liable for consequential damages of any kind, including, but not limited to, claims for property damage, personal injury, attorneys' fees, lost profits, loss of use, liability of Purchaser to customers, loss of goodwill, interest on money withheld by customers, damages related to third party claims, travel expenses, rented equipment, third party contractor's fees, or unauthorized repair service or parts. The Purchaser, by acceptance of delivery, assumes all liability for the consequences of the use or misuse of Vaughan Co. products by the Purchaser, its employees or others.

Equipment and accessories purchased by Vaughan Co. from outside sources which are incorporated into any Vaughan pump or any pump part are warranted only to the extent of and by the original manufacturer's warranty or guarantee, if any, which warranty, if appropriate, will be assigned by Vaughan Co. to the Purchaser. It is Purchaser's responsibility to consult the applicable product documentation for specific warranty information. Specific product documentation is available upon request. Any warranty shall be void if the total contract amount is not paid in full.

Vaughan Co. neither assumes, nor authorizes any person or company to assume for it, any other obligation in connection with the sale of its equipment with the exception of a valid Vaughan "Performance Guarantee" or "Extended Warranty," if applicable. Any other enlargement or modification of this warranty by a representative or other selling agent shall not be legally binding on Vaughan Co.

Warranty eligibility determination is at Vaughan Co.'s sole discretion.

Warranty Limitations:

This warranty shall not apply to any pump or pump part which has been subjected to or been damaged by any of the following non-exclusive list of causes:

- Misuse
- Abuse
- Accident
- Negligence
- Operated in the dashed portion of the published pump curves
- Used in a manner contrary to Vaughan's printed instructions
- Defective power supply
- Improper electrical protection
- Improper storage
- Faulty installation, maintenance, or repair
- Wear caused by pumping abrasive or corrosive fluids or by cavitation
- Dissatisfaction due to buyer's remorse
- Damages incurred during transportation
- Damages incurred during installation or maintenance

THIS IS VAUGHAN CO.'S SOLE WARRANTY AND IS IN LIEU OF ALL OTHER WARRANTIES, EXPRESSED OR IMPLIED, WHICH ARE HEREBY EXCLUDED INCLUDING IN PARTICULAR ALL WARRANTIES OF MERCHANTABILITY OR FITNESS FOR A PARTICULAR PURPOSE.

