

## TURBO AGITATOR

### INSTALLATION, OPERATION & MAINTENANCE MANUAL

---

#### VAUGHAN COMPANY INC.

364 MONTE-ELMA ROAD, MONTESANO,  
WASHINGTON 98563  
PHONE: (360) 249-4042; FAX: (360) 249-6155;  
[WWW.CHOPPERPUMPS.COM](http://WWW.CHOPPERPUMPS.COM)



**TABLE OF CONTENTS**

**INSTALLATION, OPERATION, and MAINTENANCE INSTRUCTIONS**

**1. IMPORTANT SAFETY INFORMATION** ..... Page 3

**2. DESCRIPTION OF VAUGHAN TURBO AGITATOR** ..... Page 6

- A. Description of Major Components
- B. Proper Applications for Vaughan Turbo Agitator
- C. Use of Vaughan Turbo Agitator that May Cause Trouble
- D. Expected benefits of Vaughan Turbo Agitator

**3. INSTALLATION INSTRUCTIONS** ..... Page 9

- A. Receipt Inspection
- B. Storage Considerations
- C. Turbo Mounting
- D. Motors and Controls
- E. Auto Oil Level Monitor

**4. STARTUP INSTRUCTIONS** ..... Page 11

**5. NORMAL OPERATION OF TURBO** ..... Page 12

- A. Noise
- B. Vibration
- C. Motor Overloads
- D. Oil Usage

**6. STARTUP & CERTIFICATION CHECKLIST** ..... Page 14

**7. SHUTDOWN INSTRUCTIONS** ..... Page 15

- A. Manual Shutdown
- B. Automatic Shutdown
- C. Emergency Shutdown

**8. MAINTENANCE** ..... Page 15

- A. Routine Maintenance
- B. Corrective Maintenance

**9. TROUBLESHOOTING** ..... Page 16

**10. WARRANTY** ..... Page 18

---

## IMPORTANT INFORMATION FOR INSTALLERS OF THIS EQUIPMENT!

This equipment is intended for installation by technically qualified personnel. Failure to install it in compliance with national and local electrical codes, building codes and within Vaughan Co. recommendations may result in electrical shock, personal injury or death, fire hazard, unsatisfactory performance, and equipment failure. If further assistance is required contact your local representative or Vaughan Co. *Keep this manual in a safe location for future reference.*

**⚠ DANGER** Indicates a hazard, which, if not avoided, will result in death or serious injury.

**⚠ WARNING** Indicates a hazard, which, if not avoided, could result in death or serious injury.

**⚠ CAUTION** Indicates a hazard, which, if not avoided, may result in minor or moderate injury or damage to the equipment.

**NOTICE** Indicates special operation or maintenance information.

- Isolate the pump hydraulically and electrically before servicing or inspecting pump. Lock out both power source and isolation valves.
- This pump may handle dangerous or contaminated fluids. There are sharp corners, edges and pinch areas which can cause serious injury. Be careful; wear protective gloves whenever possible. If you cut yourself, seek medical help immediately to avoid serious infection.
- This pump may start automatically if wired to float switches or other equipment. Before inspecting or making adjustments disconnect electrical power and lock out circuit breakers to pump motor and associated equipment. Duplex pumps with alternating relays must both be locked out; otherwise the pump you are working on may not be isolated and could start as “the alternate”. Visually confirm that the pump has come to a complete stop before proceeding.
- Motors may be equipped with built-in thermal overloads to shut off the motors in the event the temperature gets too high (as a result of low voltage, poor ventilation, overloaded lines, etc.) These motors can restart automatically as the motor cools down. DO NOT work on the pump or motor without first disconnecting and locking out the power supply.
- Enter tanks or pits with extreme caution and only after an instrument check of the pit/tank has been completed to verify the absence of dangerous gases and the presence of safe levels of oxygen. Never enter a tank or pit without a safety harness and lifeline, and an air pack. Never enter the pit without rescue personnel standing by. Follow all national and local requirements for confined space entry.
- Keep all pit openings covered when not in use. In addition to the injuries from falling, pits may contain poisonous gases or liquids.
- Rotating Turbo: Locking mechanism must be in place prior to lifting.

- The pump is to always be lifted using adequate crane and sling capacity. All applicable safe hoisting practices should be employed. When doing so, rig the load to prevent flipping. Do not use the motor lifting eyes to lift the assembled pump. Use the motor lifting eyes to lift the detached motor only. Cast-in lifting eyes are designed for lifting individual pump components or sub-assemblies, not the entire pump. Only base-mounted lifting eyes may be used to lift a pump and drive assembly.

**OR**

- Lift pump and motor by pump lifting bail only. Lifting by any other parts of this equipment is dangerous and may damage equipment. Inspect the lifting bail to be sure it is not damaged. Replace immediately if the bail is weakened in any way.
- Do not allow people under the pump assembly while it is being lifted.
- Pump components can be heavy. Proper methods of lifting must be employed to avoid physical injury and/or equipment damage. Steel toed shoes should be worn at all times.
- Do not allow liquid to be trapped in pump or piping between two closed valves. Always drain or vent the piping/pump between two closed valves. Failure to vent or drain could allow dangerous pressures to build causing rupture damage resulting in injury, death, and equipment damage.
- Never operate a pump with closed or blocked discharge valves. This will destroy the pump and could be dangerous to personnel.
- Safety apparel to be worn when working on or making adjustments to pumps should include:
  - Heavy work gloves when handling parts with sharp edges, especially impellers.
  - Safety glasses (with side shields) for eye protection
  - Steel-toed shoes for foot protection when handling parts, heavy tools, etc.
  - Other personal protective equipment to protect against hazardous/toxic fluids and gases.
- Do not operate this equipment unless safety guards or devices are in place and properly adjusted.
- Let the pump cool to ambient temperature before beginning work on it. A warm pump can contain compartments of pressurized fluid, which may vent violently during disassembly.
- Never apply heat to remove parts unless specifically directed to do so in overhaul instructions. Use of heat may cause an explosion due to trapped fluid, resulting in severe physical injury and property damage.
- Pressure may build up in the standard mechanical seals used in Vaughan pumps. Whenever checking or maintaining the oil in the Vaughan Cartridge Seal, or the welded metal bellows seal with seal oil chamber, make sure the pump and seal are cool to the touch. Use care when removing the oil chamber plugs and pressure relief

valve, in case any residual pressure exists. If pressure exists, the plug could become a projectile and/or contaminated oil could spray.

- As it is possible to run Vaughan Chopper and Screw pumps dry, for quality assurance or troubleshooting reasons, it is extremely important to ensure suction and discharge connections are always properly guarded to prevent anything (i.e. foreign objects or pump parts) from being thrown from the pump as a projectile. All pumps must be run with suction and discharge piping in place, or blind flanges installed on suction and discharge connections. Blind flanges should be vented to avoid pressure build-up. Note that cast rotating parts could break if metal to metal contact occurs while the pump is running dry.
- Shut pump off when adjusting fittings to avoid being sprayed with pumpage. Pumped materials may be hot, corrosive, poisonous, infectious, or otherwise dangerous to personnel.
- Pump motors are connected to high voltage. Allow only qualified electricians to service this electrical equipment only in accordance with the latest revision of the National Electrical Code and other applicable requirements.
- Make certain all personnel are clear of equipment before operating.
- This equipment may not meet explosion proof requirements for hazardous environments unless specifically ordered for this purpose. Introducing non-explosion proof equipment into a hazardous environment as defined by the National Electrical Code can cause a dangerous explosion.
- This pump uses oil which, if spilled, can cause a slipping hazard and danger to personnel.
- Keep hands, feet and clothing away from moving machinery.
- Never clean, oil, adjust, or repair machinery while in motion.
- Keep electrical control panel area clear to avoid to avoid hazard to personnel. If a person should trip and fall into an open panel enclosure, serious electrical burns can result.
- Keep electrical control panel doors closed except to make adjustments or repairs by a qualified electrician.
- Overheated pumps can cause severe burns and injury. If overheating of pump casing occurs:
  - 1) Shut down pump immediately.
  - 2) Wait for pump to cool to air temperature.
  - 3) Slowly and cautiously vent pump at drain plug.
  - 4) Trouble shoot cause of overheating.

***If there are any questions regarding the safe and proper methods for operating or servicing this pump, please contact Vaughan Company for assistance.***

## DESCRIPTION OF VAUGHAN TURBO AGITATOR

The Vaughan Turbo Agitator is specifically designed for mixing trash laden material in wet pits in industrial, agricultural, and municipal plants. The Turbo is a low-speed, low-pressure axial-flow propeller pump which has a vertical shaft and which encloses the propeller inside a large elbow. The unit is supplied with a deck plate to mount the Turbo, the motor and drive system, and the automatic oil level monitor (for Turbo shutdown in case of seal failure). Mixing and homogenization of solids-laden slurries is particularly helpful in pits to eliminate buildup of sediment. The Turbo also helps to mix in floating debris. Homogenization of slurries is fundamentally important for reliable pumping. (Note that the Turbo cannot pump out your pit.) Mixing also helps to improve digestion, heat transfer, and aeration, depending on the process. The Turbo incorporates a couple of patented cutters to minimize wrapping, fouling, blockage, vibration, and motor overload.

### A. DESCRIPTION OF MAJOR COMPONENTS

Note: Please use the Turbo-S exploded assembly parts list as an aid in understanding this section.

**PROPELLER:** The propeller on the Vaughan Turbo induces mixing flow by drawing liquid into the Turbo elbow and then accelerating the fluid through the elbow to create mixing flow.

**UPPER CUTTER:** The upper cutter ring (mounted in a threaded holder and then bolted to the bearing housing) uses two cutting dogs to cut against cast-in teeth located on the rotating cutter/thrust washer located at the top side of the propeller. This keeps debris from wrapping above the propeller and causing seal problems.

**CASING CUTTER INSERT:** The casing

cutter is adjustable with shims and cuts against the rotating Turbo propeller to remove debris that wraps on the outside of the propeller. Without this cutter wrapped material can get trapped between the propeller blades and the inside surface of the elbow casing, causing binding, vibration, and possible motor overload from excess friction and the resulting torque increase. **NOTE: Adjust this cutter ONLY with the Turbo mixer pulled out of the pit.**

**MECHANICAL SEAL DESIGN:** Vaughan Turbo-S mixers use a high quality Vaughan-designed cartridge mechanical seal to isolate and protect the oil-bath ball bearing system from contamination from the mixed slurry. The seal is located immediately above the Turbo propeller on the Turbo shaft. Mechanical seal faces are made of solid silicon carbide for long life in abrasives. The best indication of any problems with the mechanical seal system is a loss of oil from the Turbo stem (or column). The Turbo thrust washer includes pumpout vanes designed to pull oil out of the Turbo stem if a seal failure occurs.

**AUTO OIL MONITOR SYSTEM:** Vaughan Co. uses an automatic oil monitor system to monitor oil level and to give immediate indication of a problem if and when it occurs. Oil is monitored by a reed switch float in the oil reservoir located at the deck plate. Electrical connection to this oil switch is through a watertight Woodhead connector mounted above the deck plate. Since the oil switch has only a 50 watt capacity, shutdown of Turbo motor (i.e., interruption of motor starter operation) is generally accomplished with a standard 110 VAC. control relay, which Vaughan supplies with the Turbo. If an explosion proof motor is supplied with this Turbo, then an intrinsically safe relay will be supplied so that there is no chance of having a spark in the reed switch in a hazardous environment. A schematic showing a possible controls setup for the auto oil system is shown on the next page.

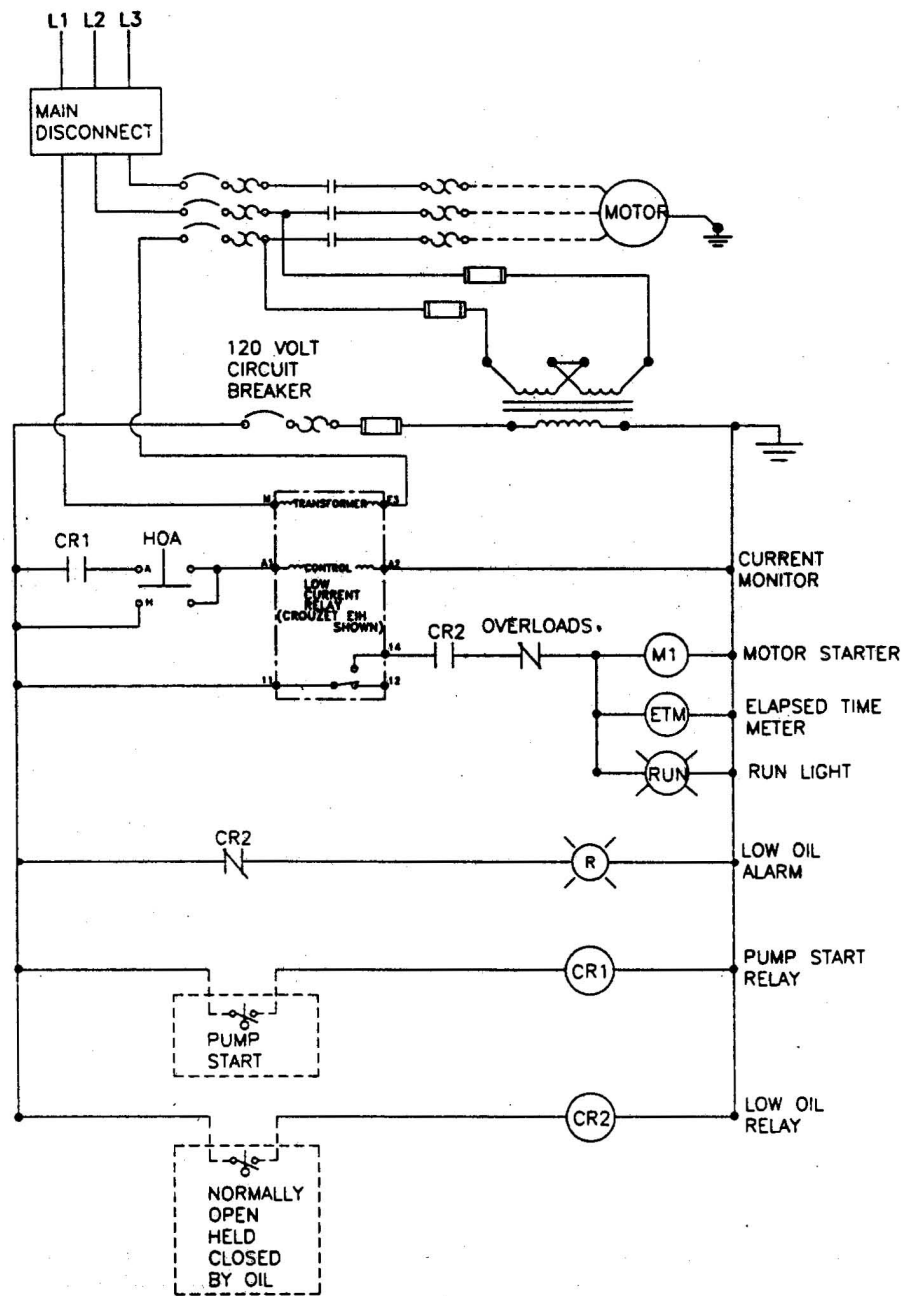

Form V328

- 7 -

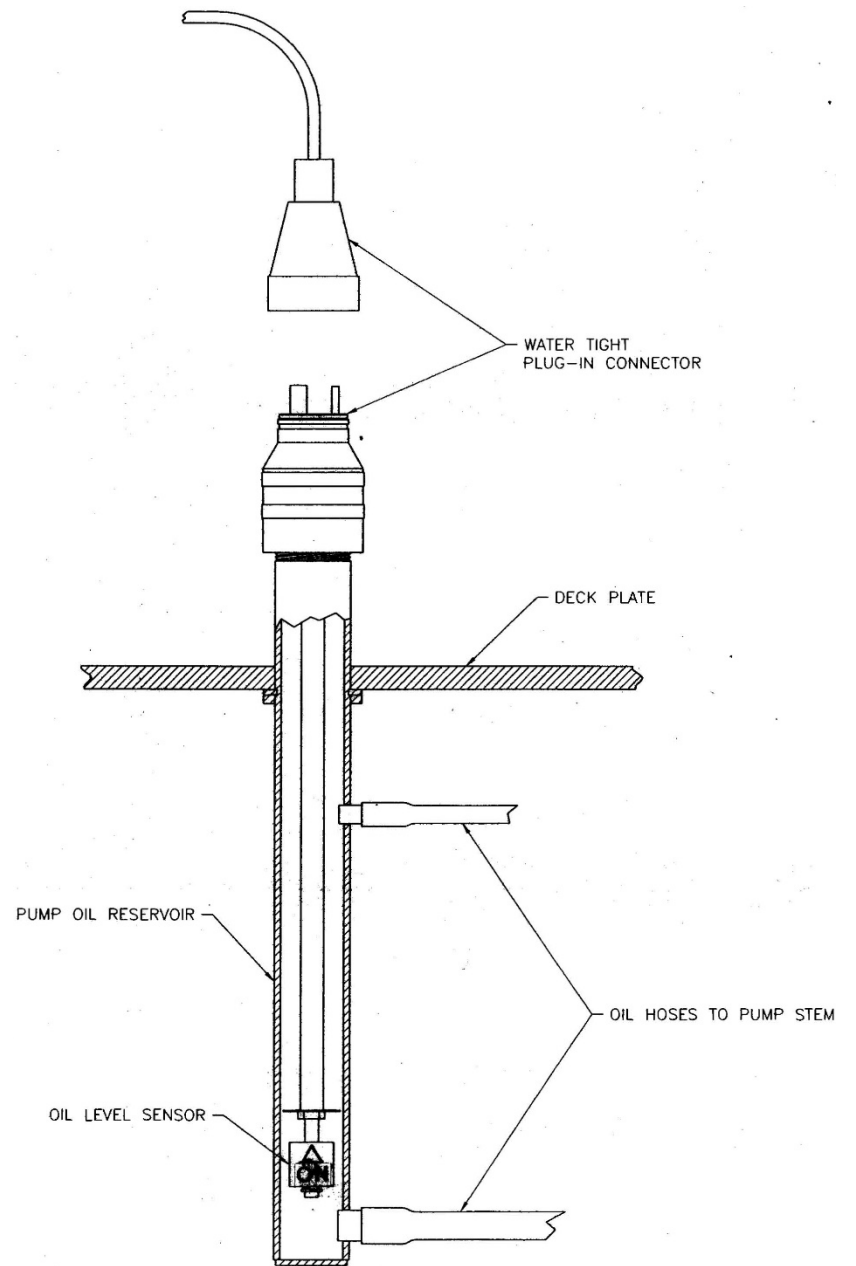

Rev 9, ECN 5294 5/24/23

**MOTOR MOUNTING:** Turbos are driven by induction type AC electric motors. They can be belt-driven or directly-driven using a gearmotor. Gearmotor driven Turbos use a C-Face bolted to a machined and piloted motor stool, which in turn is mounted to the deck plate. The Turbo is driven by the motor through an elastomeric (TB Woods "Sure-Flex or equal) coupling. The gearmotor and motor stool are aligned to the shaft and Turbo column by machined, rabbeted fits so that gearmotor and Turbo shaft alignment is automatically assured.

### **B. PROPER APPLICATIONS FOR VAUGHAN TURBO AGITATORS**

Vaughan Turbos are used for mixing liquid slurries contaminated with debris. Turbos can be used to mix the following slurries:

1. Sewage and sewage sludges.
2. Fish waste.
3. Vegetable waste.
4. Mill scale.
5. Aluminum chips from machining operations.
6. Oil sludges in oil refineries.
7. Wood chips and paper waste.
8. Animal manures (dairy cow, pigs, and chicken).
9. Feathers mixed with blood and water in poultry plants.
10. Plastic debris.
11. Coal slurry.

### **C. USES OF VAUGHAN TURBOS THAT MAY CAUSE TROUBLE**

1. Note that there must be enough liquid in your pit so that liquid and solids are able to flow freely to the Turbo. If a slurry becomes too viscous, with too little water, piles of solids will eventually accumulate.
2. A reliable and properly sized electrical supply must be installed for the Turbo to work properly. If there is too much voltage drop because of an undersized cable or transformer, the motor will not be able to

provide full power to the Turbo and it could stall during chopping of debris. If a VFD (variable frequency drive) is used, be sure that the set points are adjusted to provide maximum possible overload capability to the motor or nuisance VFD shutdown may occur during chopping. If nuisance tripping occurs in your control panel, verify that your motor overloads are properly sized, generally for 110% of motor full load amperage rating. The circuit breaker should never trip on motor overload, as this device is supposed to provide short circuit protection, not overload protection. If your circuit breaker trips during Turbo chopping, it may need to be replaced with a larger unit if it cannot be adjusted to a less sensitive setting.

3. Wet-well level control can be troublesome in solids handling applications. Some users simply allow the Turbo to run continuously, with the Turbo snoring a combination of air and liquid at low pit levels. This mode of operation can lead to seal and bearing failures and is not recommended. Vaughan Co. has available a low-current shut-off system that eliminates the need for a low-level float switch.

### **D. EXPECTED BENEFITS OF VAUGHAN TURBOS**

Most customers who install a Vaughan Turbo see several advantages:

1. Slurry pumping is more reliable once the slurry has been mixed and is homogenous.
2. Chances of Turbo plugging or binding on tough solids or fibers are minimized because of the built-in cutters and large passageways.
3. Fewer pump and system plugging problems downstream,



- because the material is pre-mixed by the Turbo.
4. Turbos use standard T-frame AC electric motors, which are cost-effective and relatively easy to replace compared to special-purpose submersible motors used on submersible propeller mixers.
  5. Turbos can continue to mix at lower pit level compared to horizontal shaft propeller mixers. Generally a Turbo can continue to mix until liquid falls below the entrance to the elbow casing, generally set at 1 ft. above the pit floor.

## INSTALLATION INSTRUCTIONS

### A. RECEIPT INSPECTION

Prior to shipment a Vaughan Turbo is carefully crated and inspected to ensure arrival at your site in good condition. On receiving your Turbo, examine it carefully to assure that no damaged or broken parts have resulted from shipping or handling. Look for signs that the Turbo has been dropped, such as damaged crating, missing paint, dented components, cracked housings, or leaking oil. Turn the Turbo shaft by hand and verify that it turns over smoothly. If damage has occurred, report to your carrier immediately, and consult your local Vaughan representative or call Vaughan Co. for advice.

### B. STORAGE CONSIDERATIONS

If equipment is to be stored for longer than two weeks, take the following action:

1. Rotate the motor 1-1/4 turn once each month to keep the bearings from sitting in one position for extended periods of time.
2. Avoid storing rotating equipment near other vibrating equipment. The vibrations can damage the ball bearings and result in premature failure once the equipment is started.

3. Store rotating equipment in a clean, dry, heated area away from areas where it could be damaged from impact, smoke, dirt, vibration, corrosive fumes or liquids, or from condensation inside the motor or Turbo. It may be helpful to cover equipment with plastic.
4. The Turbo column and bearing housing are assembled as an oil-filled assembly so that the seal and lower bearings are covered in oil. To avoid bearing corrosion these housings should be kept filled with ISO Grade 46 turbine oil to normal levels. (Note that the top bearing is grease lubricated. An air gap should be left below the top two bearings. Do not over fill.)

### C. TURBO MOUNTING

The Vaughan wet-well Turbo is heavy and will require lifting equipment to lift it into position over your pit. On a Rotating Turbo, locking mechanism must be in place prior to lifting. Lifting the Turbo by the lifting eyes on the deck plate is the only recommended method for lifting. If the Turbo is long, it's advisable to support the center of the Turbo column during lifting to avoid bending any of the stem sections. ***Do not lift by the motor lift eye.***

When locating the Turbo in the pit, position the Turbo so that the lower Turbo elbow/casing is located at least 12" away from the nearest vertical wall in the pit. Turbo length should have been chosen so that the Turbo elbow/casing inlet is located about 12" above the pit floor. Mounting the Turbo intake too close to the pit floor can cause vibrations and keep material from getting into the Turbo.

The Turbo deck plate should be bolted or clamped to the upper deck or pit cover to minimize operational vibrations. Vaughan Co. typically recommends 1/2" expansion-type anchors for use in concrete.

The exact details of your Turbo, (i.e., parts breakdown, outline dimensions, and

weight) are available from Vaughan Co. The illustration below shows a belt-driven Turbo installation mounted on a frame off the tank wall.



The illustration below shows a belt-drive Turbo mixer mounted on a concrete tank cover.



The illustrations below show how the Turbo mixer should be mounted in various tanks. Mounting the Turbo near a corner helps to minimize settling in the tank.

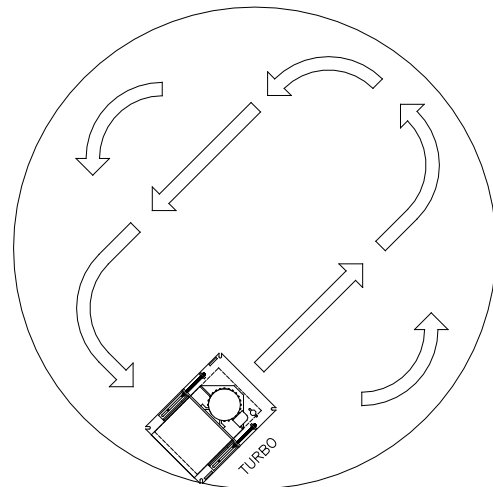
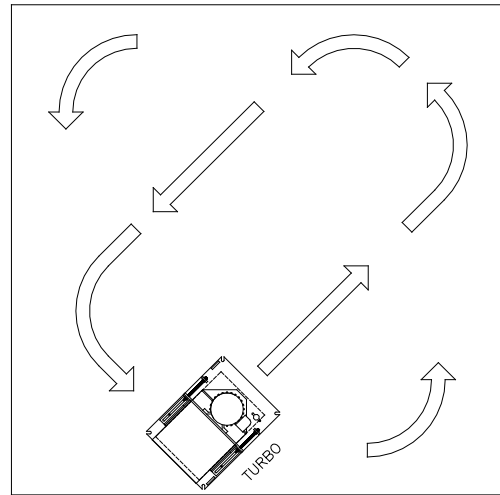
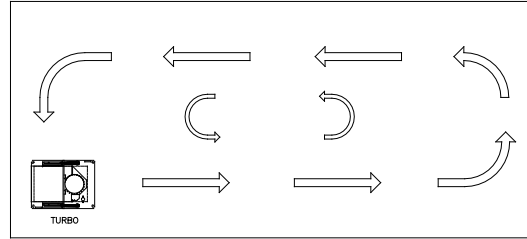
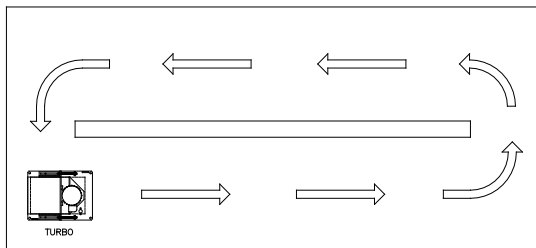

#### D. MOTOR AND CONTROLS

Most motors provided on Vaughan Turbos are not designed for hazardous environments nor rated as explosion proof. However, some applications require explosion-proof motors. If your Turbo is located in a hazardous location, be sure you ordered and received your Turbo with an explosion-proof motor and that you use an electrician experienced in hazardous environment wiring and controls.

Vaughan Turbo motors require motor protection with correctly sized breakers, starters, and overload protection. A Turbo can jam and stall on material too tough to chop through. Therefore, carefully chosen overload protection for your expensive motor is critical to avoid motor burnout. Note that nuisance tripping during chopping can occur if you do not have an adequately sized and adjusted circuit breaker. The circuit breaker should never open during chopping, it should generally be sized for 125% of motor full load amperage rating, and it should only open during a short circuit, not during motor overloads. The starter overloads should trip out on motor overload, and are typically size for 110% of motor full load amperage rating.

If your Turbo and motor are located in a hazardous environment, be sure that the control relay used for the Auto Oil Monitor System is an "intrinsically safe" relay. See the next section on the Auto Oil Monitor System Installation.

### **E. AUTO OIL LEVEL MONITOR**

The Vaughan Automatic Oil Level Monitor (OLM) System constantly monitors oil level in the Turbo column and bearing housing below the deck plate level. The auto OLM system is designed to shut the Turbo down whenever oil level drops below a preset level, but to make this system work, your electrician must connect the OLM to your controls. If desired, your controls can be set up to actuate an alarm on low oil level to alert the operators of a problem in the mechanical seal system.

The OLM system is composed of a small liquid level switch, mounted in the oil reservoir, and of a control relay, mounted in your control panel with the motor controls. Vaughan Co. supplies both the Turbo-mounted oil monitor/oil reservoir with connectors, and the control relay with 8-pin base for mounting in the customer's panel. The Auto OLM system allows the Turbo to operate normally as long as the oil level is

at an acceptable level in the reservoir. However, on loss of oil, usually due to seal damage, the oil level drops, the oil switch then opens, the control relay in the panel becomes de-energized, and the control relay contacts wired in series with the Turbo motor starter open up and interrupt voltage to the starter. This sequence of events shuts down the Turbo. The schematic presented earlier in this manual illustrates how Vaughan Co. intends this system to work.

## **STARTUP INSTRUCTIONS**

### **NOTES:**

1. Verify that belts are properly tightened and aligned prior to startup. The bill of materials lists the correct belt pull. A straightedge should touch all 4 sides of the two sheaves, indicating proper alignment. Please note that gearbox driven Turbos are designed and built for automatic alignment of motor and Turbo shafts during assembly.
2. Vaughan Co. uses Chevron GST-46 Turbine Oil in the Turbo column. Other equivalent oils are: Shell Turbo 46 = Texaco Regalo:1B = Gulf Harmony 46 = Exxon Teresstic 46. Note also that this turbine oil is completely compatible with mineral based hydraulic oils, so it is acceptable to add an equivalent weight hydraulic oil. (Do not overfill; add only enough oil to cover the switch plus 1".) The Turbo is shipped from the factory with oil, but once the Turbo is installed in your pit, it may need additional oil to make sure the oil monitor switch is covered with oil.
3. Do not completely fill the Turbo column with oil. Fill only until the float switch is covered with oil plus one additional inch. The Turbo requires some air space at the top of the Turbo column to avoid over-pressurizing the system during heat-up of the oil. The upper bearings are grease lubricated so over-filling will wash out the grease.

4. When performing the Turbo rotation check to ensure that the Turbo is turning Clockwise (as viewed from the motor end). At the control panel, push the "ON" button, then the "OFF" button as fast as possible in sequence to merely "jog" or "bump" the motor. If the motor turns clockwise, then you are ready to start the Turbo. If the motor turns counter-clockwise, (wrong direction), then have your electrician open the circuit breakers to the motor panel using your plant's normal safety precautions for locking and tagging out breakers, and then reverse any two leads to the motor starter in the control panel. Then re-close the breakers to the panel, and recheck the motor direction to be sure it's correct. If the Turbo is allowed to run backwards for any significant length of time, the propeller can unscrew from the shaft and fall into the pit. **Follow all safety precautions if you need to recover the propeller from the pit.**
5. When the STARTUP AND CERTIFICATION CHECKLIST is completed satisfactorily, review the safety warnings at the beginning of this manual and then start up the Turbo. Please fill out the STARTUP AND CERTIFICATION CHECKLIST which follows and send a copy of it to: STARTUP@CHOPPERPUMPS.COM. We will review your installation to make sure the Turbo is working properly in your system to protect your investment.

## NORMAL OPERATION

**A. NOISE:** Vaughan Turbos are normally quiet running (<85 dbA), and the major source of noise is the electric motor. Vibrations and noise could indicate that the Turbo parts have gotten wrapped with debris or the Turbo propeller may be binding on fiber. (However, mechanical vibrations should be minimal during normal operation.) Note that some chopping

operations may be noisy.

**B. VIBRATION:** Vibration, like noise, should be minimal in the Turbo unless the Turbo is doing heavy chopping. If large pieces of wood or a cow leg wrap needs to be chopped, the Turbo motor could stall on overload. In this case the Turbo will have to be pulled from the pit to clear the jam. Do not reverse the Turbo or the propeller could unwind and fall into the pit. Any chopping conditions will create vibration. But this condition may only be temporary, and the chopping action of the Turbo normally clears the obstruction with time unless the Turbo is worn out.

Please note that every effort has been made at the factory to ensure that this Turbo operates smoothly and without vibration. For example, all propellers are dynamically balanced after machining to less than 0.1 ounce of imbalance. Component alignment from top to bottom is assured by the machining methods we use. And the Turbo shaft is very tightly held by ball bearings so that there is virtually no shaft movement.

**C. MOTOR OVERLOADS:** A motor overload is not part of normal operation, but can happen more often in a Turbo than in other types of propeller mixers because of unpredictable chopping demands. If you find that the motor has tripped out on overload, when you restart the motor, have an electrician check operating amps. Make sure that the motor is not pulling more than max. allowable full load amps as indicated by the motor nameplate. Note especially that repeatedly resetting the motor overload devices and restarting the motor when it trips out again will burn out the motor! Please pull the Turbo up out of the pit and see if something unchoppable is stuck in the Turbo.

**D. OIL USAGE:** The Turbo will not use oil when the mechanical seal is in good condition. (Perhaps after a year of operation, one or two ounces of oil might be required to bring oil up to the original



DATE: \_\_\_\_\_

Project Name: \_\_\_\_\_ Location: \_\_\_\_\_

Pump S/N: \_\_\_\_\_ Equipment ID/Tag#: \_\_\_\_\_

Startup Performed By: \_\_\_\_\_

Customer Contact Info \_\_\_\_\_

Contractor Contact Info \_\_\_\_\_

Engineer Contact Info \_\_\_\_\_

### **PRE-STARTUP CHECKLIST**

- Was rotating equipment stored in a clean, dry heated area away from areas where it could be damaged from impact, smoke, dirt vibration, corrosive fumes, or liquids, or from condensation inside the motor or pump?  
Yes \_\_\_\_\_ No \_\_\_\_\_
  - If no, are you aware of any damage the equipment may have sustained?
  
- Was the shaft rotated 1-1/4 turn once each week? Yes \_\_\_\_\_ No \_\_\_\_\_
  - If no, how often was the shaft rotated?
  
- Was the exposed steel covered with a light layer of grease or Cosmoline to protect the equipment from corrosion?  
Yes \_\_\_\_\_ No \_\_\_\_\_
  
- Was the bearing housing kept filled with ISO Grade 46 hydraulic oil (does not apply to SE Submersibles)?  
N/A \_\_\_\_\_ Yes \_\_\_\_\_ No \_\_\_\_\_



Date \_\_\_\_\_

Project Name: \_\_\_\_\_ Location: \_\_\_\_\_

Turbo S/N: \_\_\_\_\_ Equipment ID/Tag#: \_\_\_\_\_

Turbo S/N: \_\_\_\_\_ Equipment ID/Tag#: \_\_\_\_\_

Startup Performed By: \_\_\_\_\_

Customer Contact Info \_\_\_\_\_

Contractor Contact Info \_\_\_\_\_

Engineer Contact Info \_\_\_\_\_

### TURBO-S VERTICAL MIXER STARTUP & CERTIFICATION CHECKLIST

Email completed form to: [STARTUP@CHOPPERPUMPS.COM](mailto:STARTUP@CHOPPERPUMPS.COM)

- Shaft turns freely by hand? Yes \_\_\_\_\_ No \_\_\_\_\_
- All guards are in place? Yes \_\_\_\_\_ No \_\_\_\_\_
- Is column properly filled with oil? Yes \_\_\_\_\_ No \_\_\_\_\_
- Is Auto Oil Level monitor properly connected and functioning? Yes \_\_\_\_\_ No \_\_\_\_\_
- Turbo is no closer than 12" off the floor? Yes \_\_\_\_\_ No \_\_\_\_\_
- Belt drive has been properly tensioned and aligned? Yes \_\_\_\_\_ No \_\_\_\_\_
- Has wet well been cleared of all construction debris? Yes \_\_\_\_\_ No \_\_\_\_\_
- Rotation has been confirmed (from motor end) per the chart below Yes \_\_\_\_\_ No \_\_\_\_\_

Turbo	Reverse Turbo
5.5, 7.5, 11, 15, KW TEFC w/ Gearbox Clockwise <input type="checkbox"/>	5.5, 7.5, 11, 15, KW TEFC w/ Gearbox Counter Clockwise <input type="checkbox"/>
18.5 KW TEFC w/ Gearbox Counter Clockwise <input type="checkbox"/>	18.5 KW TEFC w/ Gearbox Clockwise <input type="checkbox"/>
Belt Drive (All) Clockwise <input type="checkbox"/>	Belt Drive (All) Counter Clockwise <input type="checkbox"/>

#### ELECTRICAL DATA

Motor Manufacturer: \_\_\_\_\_

Motor Model Number \_\_\_\_\_

Motor Serial Number: \_\_\_\_\_

Motor HP \_\_\_\_\_ Motor RPM: \_\_\_\_\_ Frame Size \_\_\_\_\_

Nameplate Voltage: \_\_\_\_\_ Nameplate F.L. Amperage: \_\_\_\_\_

Operating Voltage: L1 – L2: \_\_\_\_\_ L2 – L3: \_\_\_\_\_ L1 – L3: \_\_\_\_\_

Operating Amperage: L1: \_\_\_\_\_ L2 \_\_\_\_\_ L3: \_\_\_\_\_

Form V558, Rev. 1

ECN5288, 5/18/23

level at startup.) If the Turbo uses large amounts of oil or if the oil is contaminated, mechanical seal damage may have occurred. (Verify that the Turbo has not been flooded from the top.) If the seal is leaking, the unit should be repaired immediately to avoid more expensive repairs later. Call Vaughan Co. immediately for advice. Vaughan Co. can send out a bearing and seal system sub-assembly or a new seal overnight, if necessary, to support your operations. Should repair be necessary, please carefully follow the instructions of the Overhaul Manual. Because the Vaughan Turbo has a unique bearing and seal design, it is extremely difficult to repair the Turbo properly if you do not have detailed directions to follow.

In unusual circumstances, the oil in the reservoir may become very slightly "milky" in appearance. Generally, this happens because condensation occurs inside the Turbo column or reservoir as temperature and weather changes. If the oil is only slightly milky, it will not present any problems for the Turbo. Obviously, if too much water gets into the oil, the oil (or the seal) must be changed.

## SHUTDOWN INSTRUCTIONS

**A. MANUAL SHUTDOWN:** In the manual mode of operation, a Vaughan Turbo is shut down by pushing the "OFF" button or turning the auto/man/off switch to the "OFF" position on the front panel of your control panel. If any repair or maintenance work is to be done on the Turbo, be sure to follow all the warnings at the beginning of this manual. Be sure to turn off electrical power by opening the breaker at the control panel and by following all plant safety procedures!

**B. AUTOMATIC SHUTDOWN:** Automatic operation normally shuts the Turbo down for you, usually on low pit level. If the Turbo does not shut down when the pit is low, the

Turbo may be shut down manually, but do troubleshoot your level control system. If you are going to do any maintenance, adjustment or inspection on this Turbo or motor, be sure to follow all warnings at the beginning of this manual. Be sure to turn off electrical power by opening the main panel breaker and by following all plant safety procedures, since in the automatic mode, the Turbo could start automatically if not isolated!

**C. EMERGENCY SHUTDOWN:** In any kind of emergency when the Turbo needs to be shutdown, hit the manual "OFF" switch or pushbutton on the front of the Turbo control panel. If any work has to be done on the Turbo or motor, open the main breaker on the Turbo control panel so that the Turbo cannot automatically restart when personnel are near the Turbo or motor.

## MAINTENANCE

### A. ROUTINE MAINTENANCE

#### MONTHLY:

1. Check amperage draw to the Turbo motor and compare to that measured at startup. Make sure that power draw does not exceed allowable amperage to the motor at full load.

#### QUARTERLY:

1. Motor: Inspect electric motor. Make sure that casing drain is not plugged to ensure that motor cannot fill up with water. Clean cooling fins so that dirt buildup will not affect cooling ability of motor. Check for loose hardware and damaged wiring or conduit.

2. Turbo: Inspect Turbo for loose hardware. Disconnect power to the Auto OLM and check the oil to ensure that it is clean and at the proper level. Make sure that Turbo is operating smoothly and without vibration.

**SEMI-ANNUALLY:**

1. Grease motor bearings.
2. Perform quarterly inspections.

**ANNUALLY:**

On a Rotating Turbo, locking mechanism must be in place prior to lifting. Remove Turbo from the pit and inspect for wear or damaged parts. Check propeller clearance from cutter. It should be no greater than 0.025" max. Shim cutter closer to Turbo propeller, or replace propeller and cutter as required. Check for smooth shaft rotation by rotating the Turbo shaft by hand. Be especially alert to rough spots on the bearings. Make sure there is no axial play in the Turbo shaft and that no oil is leaking across the seal faces into the Turbo elbow. Inspect Turbo elbow for wear and replace as necessary. Check for loose hardware, and tighten and replace as necessary.

**CORRECTIVE MAINTENANCE:**

See the next page for belt tightening procedure.

Because overhaul of a Vaughan Turbo is a major undertaking, the Overhaul Instruction is a separate procedure. Please do not try to overhaul or repair the Turbo without this important procedure and without the exploded assembly parts breakdown. The overhaul manual was sent to you by mail when your order for the Turbo was placed at the factory. If you do not have a copy of this manual, please call Vaughan Co. Engineering; we will make sure you get proper instructions overnight or by email.

**TROUBLESHOOTING**

Below is a table listing problem symptoms with possible causes of these symptoms. Troubleshooting involves identifying symptoms and then going through all the possible causes to eliminate those that don't apply. Once a cause is found, take action to eliminate the cause.

POSSIBLE CAUSES	SYMPTOMS				
	UNMIXED REGIONS IN PIT	TURBO PROP FALLING OFF	TURBO VIBRATION Belts coming off sheaves	MOTOR OVERLOADING	FREQUENT LEAKING MECHANICAL SEAL
Slurry Viscosity or percent solids too high					
Presence of high specific gravity grit					
Not enough power and speed on Turbo					
Mixing obstructions in pit					
Not enough mixing time					
Poor mixer placement in pit					
Worn propeller					
Turbo prop turning wrong direction					
Fibrous binding from worn cutters on Turbo					
Turbo too close to floor					
Percent solids too high					
High specific gravity fluid					
Incorrect belt-drive speed					
Abrasive wear					



## BELT TENSIONING PROCEDURE

The Turbo is often belt-driven. Belts are typically tightened at the factory but should be rechecked prior to startup and at any time when slippage or belt noise is evident.

The procedure is as follows:

1. Remove the belt guard cover and set it aside.
2. Loosen the two threaded rod nuts on the bracket side of the two steel ears welded to the deck plate. Then tighten the two nuts on the outside of the steel ears until the belts can each be depressed approximately  $\frac{1}{2}$ " in the center by hand.
3. Place a steel straight edge across the two belt sheave centers, passing directly . If the two sheaves are in alignment, the straightedge will touch each edge of each shave. If a straightedge is not available, the edge of the belt guitar cover can be used. As long as the motor has not moved on the brackets the straightedge should show correct alignment.
4. If the straightedge doesn't touch in four places, the motor mounting will have to be adjusted. This will require lifting equipment to hold up the motor while the 4 bolts holding the feet are loosened and the motor position is adjusted to straighten out the sheaves. Please note that even a small misalignment can cause vibration and premature belt or sheave wear.
5. Once the sheaves are in proper alignment, the belt tension must be set as described in step 2 above, except this time you need to be more accurate. For proper belt tension measurement, press in the center of one belt length with a special belt tensioning spring tool such as Dodge part # 109082, shown at right. This tool is available at most industrial supply houses for about \$30. A spring scale and a tape measure can be used if the special tool is unavailable, but it is very important to set the tension correctly because incorrect tension can cause rapid belt, sheave, and bearing wear. The correct tension for your Turbo belts is on the bill of materials for your Turbo. Vaughan Co. can provide this information if you do not have it available.
6. The alignment/tensioning procedure may have to be repeated until both tension and alignment are correct, as sometimes setting one disrupts the other. Once tension and alignment are correct, reinstall the belt guard cover.

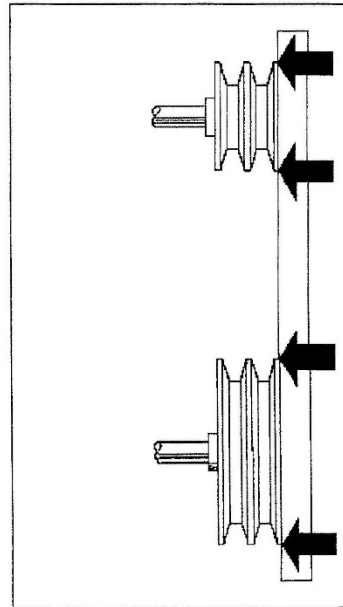
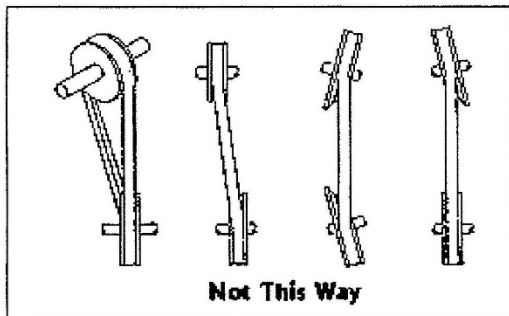
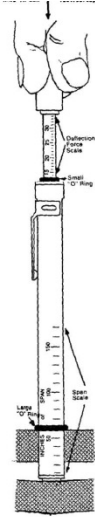



**VAUGHAN CO., INC. PRODUCT WARRANTY**

Vaughan Company, Inc. (Vaughan Co.) warrants to the original purchaser/end user (Purchaser) all pumps and pump parts manufactured by Vaughan Co. to be free from defects in workmanship or material for a period of twelve (12) months from date of startup, not to exceed eighteen (18) months from the date of shipment from Vaughan Co. Startup data must be submitted to Vaughan Co. within 30 days of startup. If Purchaser fails to submit startup data within 30 days of startup, then Vaughan, in its sole discretion, may elect to void this warranty at any time. Purchaser must contact Vaughan Co. prior to commencing any repair attempts, or removing pump or parts from service. If Purchaser fails to contact Vaughan Co. prior to commencing any repair attempts or removing pumps or parts from service, then Vaughan, in its sole discretion, may elect to void this warranty at any time.

If during said warranty period, any pump or pump parts manufactured by Vaughan Co. prove to be defective in workmanship or material under normal use and service, and if such pump or pump parts are returned to Vaughan Co.'s factory at Montesano, WA, or to a Vaughan authorized Service Facility, as directed by Vaughan Co., transportation charges prepaid, and if the pump or pump parts are found to be defective in workmanship or material, they will be replaced or repaired by Vaughan Co. free of charge. Products repaired or replaced from the Vaughan Co. factory or a Vaughan authorized Service Facility under this warranty will be returned freight prepaid. Vaughan Co. shall not be responsible for the cost of pump or part removal and/or re-installation.

All warranty claims must be submitted in writing to Vaughan Co. not later than thirty (30) days after warranty breach occurrence. The original warranty length shall not be extended with respect to pumps or parts repaired or replaced by Vaughan Co. under this Warranty. This Warranty is voided as to pumps or parts repaired/replaced by other than Vaughan Co. or its duly authorized representatives.

Vaughan Co. shall not be liable for consequential damages of any kind, including, but not limited to, claims for property damage, personal injury, attorneys' fees, lost profits, loss of use, liability of Purchaser to customers, loss of goodwill, interest on money withheld by customers, damages related to third party claims, travel expenses, rented equipment, third party contractor's fees, or unauthorized repair service or parts. The Purchaser, by acceptance of delivery, assumes all liability for the consequences of the use or misuse of Vaughan Co. products by the Purchaser, its employees or others.

Equipment and accessories purchased by Vaughan Co. from outside sources which are incorporated into any Vaughan pump or any pump part are warranted only to the extent of and by the original manufacturer's warranty or guarantee, if any, which warranty, if appropriate, will be assigned by Vaughan Co. to the Purchaser. It is Purchaser's responsibility to consult the applicable product documentation for specific warranty information. Specific product documentation is available upon request. Any warranty shall be void if the total contract amount is not paid in full.

Vaughan Co. neither assumes, nor authorizes any person or company to assume for it, any other obligation in connection with the sale of its equipment with the exception of a valid Vaughan "Performance Guarantee" or "Extended Warranty," if applicable. Any other enlargement or modification of this warranty by a representative or other selling agent shall not be legally binding on Vaughan Co.

Warranty eligibility determination is at Vaughan Co.'s sole discretion.

Warranty Limitations:

This warranty shall not apply to any pump or pump part which has been subjected to or been damaged by any of the following non-exclusive list of causes:

- Misuse
- Abuse
- Accident
- Negligence
- Operated in the dashed portion of the published pump curves
- Used in a manner contrary to Vaughan's printed instructions
- Defective power supply
- Improper electrical protection
- Improper storage
- Faulty installation, maintenance, or repair
- Wear caused by pumping abrasive or corrosive fluids or by cavitation
- Dissatisfaction due to buyer's remorse
- Damages incurred during transportation
- Damages incurred during installation or maintenance

***THIS IS VAUGHAN CO.'S SOLE WARRANTY AND IS IN LIEU OF ALL OTHER WARRANTIES, EXPRESSED OR IMPLIED, WHICH ARE HEREBY EXCLUDED INCLUDING IN PARTICULAR ALL WARRANTIES OF MERCHANTABILITY OR FITNESS FOR A PARTICULAR PURPOSE.***