

3"-6" PEDESTAL SCREW CENTRIFUGAL PUMPS

Materials of Construction:

Impeller/Casing/Suction Cone/Back Pull-Out Plate:Ductile cast iron.
Insert Cutter:Alloy steel, heat treated to minimum Rockwell C 60.
Flushless Mechanical Seal:..... Cartridge type with silicon carbide (or tungsten carbide) faces and stainless steel sleeve. (See following page for other sealing options)
Thrust Bearings: Face to face tapered roller type.
Radial Bearings:..... Ball bearing type.
Shaft: Heat treated steel.
Lubrication: ISO Grade 46 oil.
Flanges: ANSI Class 150 suction and Class 125 discharge.
Mounting Base: Carbon Steel.
Paint: Epoxy

DRAWINGS AND DIMENSIONS SUBJECT TO CHANGE WITHOUT NOTICE. DO NOT USE FOR CONSTRUCTION PURPOSES. CONTACT VAUGHAN FOR CERTIFIED CONSTRUCTION PRINTS.

MODEL	A	B	C	D	E	F	G	H
PSC3DS	39-3/4	5-3/8	13-3/8	8	8-7/16	4	3	20
PSC4DH	39-3/8	5-3/8	14	6-1/8	9-3/4	4	4	23
PSC6EM	51	12-1/4	17-3/4	13	13	6	5 & 6	29
PSC6ES	51	12-1/4	17-3/4	13	13	6	5 & 6	29

DIMENSIONS IN INCHES

MOTOR FRAME	HP	SPEED	*U	*V
182TC	3	1750	23	10
184TC	5	1750	23	10
213TC	7.5	1750	25	11
215TC	10	1750	26	11
	10	3510		
	15	1750		
	15	3510		
256TC	20	1750	32	13
	20	3510		
284TC	25	1750	33	15
284TSC	25	3510	31	15
	30	3510		
286TC	30	1750	34	15
324TC	40	1750	36	17
324TSC	40	3510	34	17

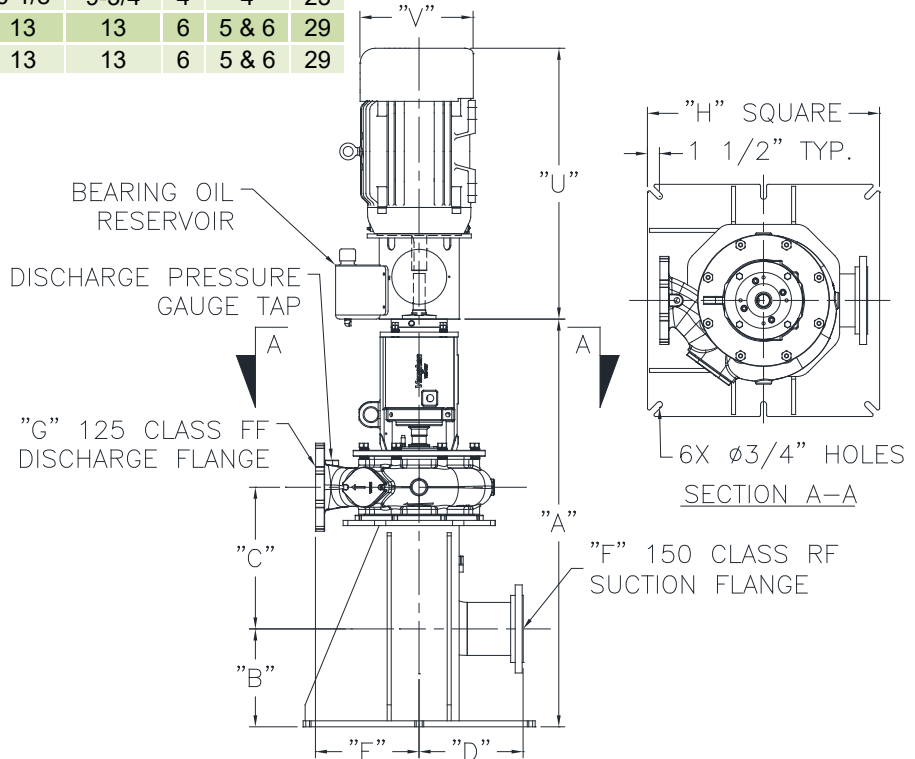

*FOR REFERENCE ONLY. DIMENSIONS WILL VARY SLIGHTLY BY MOTOR MANUFACTURER



VAUGHAN CO., INC.
 364 Monte Elma Road, Montesano, WA 98563
 Phone: 1-360-249-4042 / Fax: 1-360-249-6155
 Toll Free Phone (US only): 1-888-249-CHOP (2467)
 Web Site: www.chopperpumps.com
 Company E-mail: info@chopperpumps.com

**MADE IN THE
USA**

For all current patents, see <http://www.chopperpumps.com/patents.htm>

SPECIFICATIONS: 3"–6" PEDESTAL SCREW CENTRIFUGAL PUMPS

The Vendor shall furnish (___) pedestal, screw-centrifugal pump(s) and all appurtenances as specified. The pump(s) shall be of heavy-duty construction intended for services requiring reliable solids handling, gentle pumping action, high efficiency, and low NSPH_R. Pump shall be manufactured by Vaughan Co., Inc.

DETAILS OF CONSTRUCTION

- A. **Casing and Back Pull-Out Plate:** The pump casing shall be of volute design, spiraling outward to the Class 125 flanged centerline discharge. Casing & backplate shall be ductile cast iron with all water passages to be smooth, and free of blowholes and imperfections for good flow characteristics. A pressure tap shall be included on or near the discharge flange. Back pull-out design shall incorporate adjusting sleeves for accurate adjustment of impeller-to-suction cone clearance, and shall allow removal of pump components without requiring disconnection of casing from inlet or discharge piping. Backplate shall include a replaceable Rockwell C 60 alloy steel cutter to cut against the Rockwell 60 impeller hub cutter for removing fiber and debris.
- B. **Inlet Suction Cone:** The inlet suction cone shall be ductile cast iron with all water passages to be smooth, and free of blowholes and imperfections for good flow characteristics. The suction cone shall incorporate a spiral groove to channel trapped fiber into the casing that would otherwise bind between the impeller OD and the inlet cone ID. The clearance of impeller to inlet cone shall be externally adjustable without requiring special tools, pump disassembly or disconnection of piping.
- C. **Impeller:** Shall be open channel, screw-centrifugal. The impeller shall be ductile cast iron and shall be dynamically balanced. The single-passage impeller shall combine the action of a positive displacement screw and a single-vane centrifugal impeller.
- D. **Backplate Insert Cutter:** Shall be fitted into the back plate behind the impeller, designed to cut against a cutter in the impeller hub, reducing and removing stringy materials from the mechanical seal area. Insert cutters shall be alloy steel heat treat hardened to minimum Rockwell C 60. The insert cutter clearance from the impeller hub to back plate shall be externally adjustable without requiring pump disassembly.
- E. **Impeller Hub Cutter:** Shall be alloy steel heat treat hardened to minimum Rockwell C 60 and fitted into the impeller hub (except 3" model). Hub cutter clearance from the backplate insert cutter shall be externally adjustable without requiring pump disassembly or special tools.
- F. **Pump Shafting:** Shafting shall be heat treated alloy steel.
- G. **Stuffing Box:** Shall be ductile cast iron. The stuffing box shall be designed to accommodate the mechanical seal, or packing. Mechanical seal with no seal water flush and flushed tandem mechanical seal as described below do not require stuffing box.
- H. **Seal:** [NOTE TO CONSULTING ENGINEER: Please choose one of the four options below]:
- Mechanical Seal system specifically designed to require no seal flush: The mechanical seal shall be located immediately behind the impeller hub to eliminate the stuffing box and maximize the flushing available from the impeller pumpout vanes. The seal shall be a cartridge-type mechanical seal with Viton O-rings and silicon carbide (or tungsten carbide) faces. This cartridge seal shall be a pre-assembled, and pre-tested so that no seal settings or adjustments are required from the installer. Any springs used to push the seal faces together must be shielded from the fluid to be pumped. The cartridge shall also include a 17-4PH, heat-treated seal sleeve and stainless steel seal housing.
 - Flushed Tandem Mechanical Seal: The seal shall be cartridge-type tandem mechanical seal with Viton O-rings and silicon carbide (or tungsten carbide) faces. This cartridge seal shall be a pre-assembled and pre-tested so that no seal settings or adjustments are required from the installer. Any springs used to push the seal faces together must be shielded from the fluid to be pumped. The cartridge shall also include a 17-4PH, heat-treated seal sleeve and stainless steel seal housing. Seal requires flush to drain at 3 US gallons per hour flow rate.
 - Mechanical seal with throttle bushing and water fitting for seal water flush. The seal shaft sleeve shall be AISI 316 SS. Mechanical seal materials shall be either 316 stainless steel or Alloy 20 with silicon carbide or tungsten carbide faces. Seal shall be positively driven by set-screws. Elastomers shall be of Buna N, and stationary seal member shall be of the cup-mounted type to ensure cushioning of face material from mechanical shock. Contractor is to provide a 6-10 gal./hr. seal flush with filtered water, a rotameter, throttle valve, and solenoid operated isolation valve interlocked with an auxiliary contact of the motor starter.
 - Packing design with 5-ring packing, split Teflon lantern ring and water fitting. The packing shaft sleeve shall be 316 SS with Nickel-Chrome-Boron coating. Contractor is to provide a filtered water packing flush at 10 PSI greater than pump discharge pressure. The flush water line is to be interlocked with an auxiliary contact of the motor starter so it is automatically turned on when the motor is started.
- I. **Bearings:** Shaft thrust in both directions shall be taken up by two face to face mounted single-row tapered roller bearings. Ball bearings shall be provided for radial loads. Bearings shall be rated with a minimum L-10 bearing life of 100,000 hours at any acceptable operating point on the performance curve.
- J. **Bearing Housing:** Shall be ductile cast iron, and machined with piloted bearing fits for concentricity of all components. Bearing housing shall have oil bath lubrication using ISO Grade 46 oil, and shall include a side mounted oil reservoir. Viton double lip seals riding on stainless steel shaft sleeves are to provide sealing at each end of the bearing housing.
- K. **Inlet Manifold:** The pump assembly shall be mounted vertically with a 90 degree carbon steel elbow with a ANSI CL 150 inlet flange, cleanout, 1/2" NPT suction pressure tap, drain connection and pedestal base.
- L. **Shaft Coupling:** Bearing housing and motor stool design is to provide accurate, self-aligning mounting for a C-flanged electric motor. Pump and motor coupling shall be T.B. Woods Sureflex elastomeric type.
- M. **Stainless Steel Nameplate:** Shall be attached to the pump giving the manufacturer's model and serial number, rated capacity, head, speed and all pertinent data.
- N. **Drive Motor:** Shall be ___ HP, ___ RPM, ___ volts, 3 phase, 60 hertz, 1.15 service factor, C-flange mounted, TEFC enclosure. The motor shall be sized for non-overloading conditions.
- O. **Surface Preparation:** Solvent wash and a single coat of Tnemec 431 epoxy (except motor).
- P. **OPTIONAL Premium Surface Preparation:** Solvent wash, sandblast, and coat with minimum 30 MDFT Tnemec Perma-Shield PL Series 431 epoxy. (except motor).