

## 3"-6" VERTICAL WET WELL SCREW CENTRIFUGAL PUMPS

### Materials of Construction:

**Impeller/Casing/Suction Cone/Back Pull-Out Plate:** .....Ductile cast iron.  
**Insert Cutter:** .....Alloy steel, heat treated to minimum Rockwell C 60.  
**Mechanical Seal:** .....Cartridge type with silicon carbide (or tungsten carbide) faces and stainless steel sleeve. (See following page for other sealing options)  
**Thrust Bearings:** .....Angular contact ball type or tapered roller type.  
**Radial Bearings:** .....Ball bearing type.  
**Shaft:** .....Heat treated alloy steel.  
**Lubrication:** .....ISO Grade 46 oil.  
**Flanges:** .....ANSI Class 150 discharge.  
**Deck Plate:** .....Carbon Steel.  
**Paint:** .....Epoxy

**DRAWINGS AND DIMENSIONS SUBJECT TO CHANGE WITHOUT NOTICE. DO NOT USE FOR CONSTRUCTION PURPOSES. CONTACT VAUGHAN FOR CERTIFIED CONSTRUCTION PRINTS.**

MODEL	A	B	C	D	E	F	G	H	J
VSC3DS	14	22	24	20	10	3	4-1/8	14	1/2
VSC4DH	16	25	30	20	10	4	5-1/2	16	1/2
VSC6EM	20-1/2	32-1/2	40	26	13	6	8-5/8	20	3/4
VSC6ES	20-1/2	32-1/2	40	26	13	6	8-5/8	20	3/4

### BAFFLE RING REQUIREMENT

	MINIMUM FLOW	SIZE
VSC3DS	200 GPM	10" – 14"
VSC4DH	300 GPM	12" – 16"
VSC6EM	400 GPM	14" – 20"
VSC6ES	400 GPM	14" – 20"

### DIMENSIONS IN INCHES

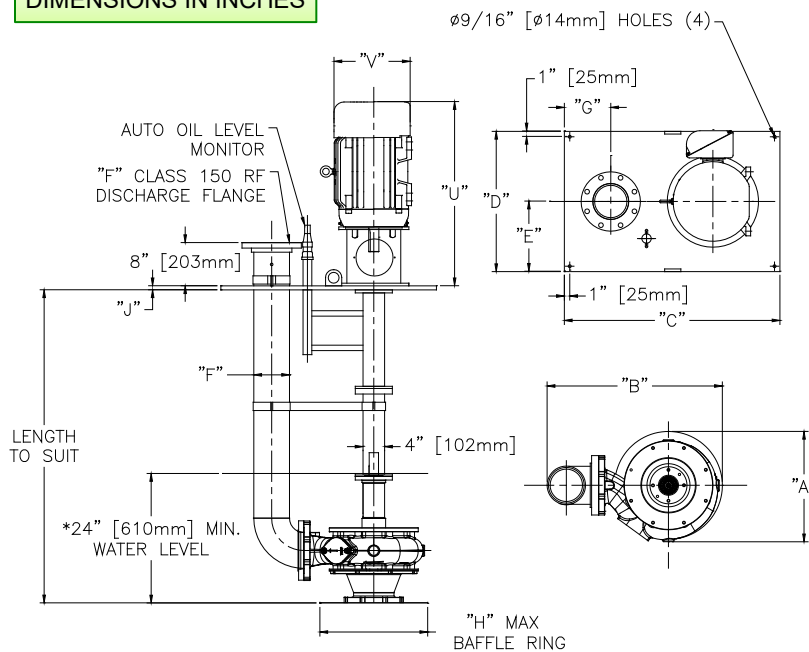

MOTOR FRAME	HP	SPEED	*U	*V
184TC	5	1750	23	10
213TC	7.5	1750	25	11
215TC	3	870	26	11
	5	1170		
254TC	7.5	1170	30	13
	15	1750		
256TC	10	1170	32	13
	20	1750		
	20	3510		
284TSC	25	3510	32	13
286TC	30	1750	34	15
286TSC	30	3510	34	15
324TC	40	1750	36	17
324TSC	40	3510	36	17

\*VSC3DS 12" SUBMERGENCE REQUIRED BELOW 600 GPM  
 \*VSC4DH 12" SUBMERGENCE REQUIRED BELOW 700 GPM  
 \*VSC6EM 12" SUBMERGENCE REQUIRED BELOW 1100 GPM  
 \*VSC6ES 12" SUBMERGENCE REQUIRED BELOW 1100 GPM

\*FOR REFERENCE ONLY. DIMENSIONS WILL VARYSLIGHTLY BY MOTOR MANUFACTURER



**VAUGHAN CO., INC.**  
 364 Monte Elma Road, Montesano, WA 98563  
 Phone: 1-360-249-4042 / Fax: 1-360-249-6155  
 Toll Free Phone (US only): 1-888-249-CHOP (2467)  
 Web Site: [www.chopperpumps.com](http://www.chopperpumps.com)  
 Company E-mail: [info@chopperpumps.com](mailto:info@chopperpumps.com)

For all current patents, see <http://www.chopperpumps.com/patents.htm>

**MADE IN THE  
USA**

## SPECIFICATIONS: 3"-6" VERTICAL WET WELL SCREW CENTRIFUGAL PUMPS

The Vendor shall furnish ( ) vertical wet pit, screw-centrifugal pump(s) and all appurtenances as specified below. The pump(s) shall be of heavy-duty construction intended for services requiring reliable solids handling, gentle pumping action, high efficiency, and low NSPHR. Pump shall be manufactured by Vaughan Co., Inc.

### DETAILS OF CONSTRUCTION

- A. Casing and Back Pull-Out Plate:** The pump casing shall be of volute design, spiraling outward to the class 125 flanged centerline discharge. Casing & backplate shall be ductile cast iron with all water passages to be smooth, and free of blowholes and imperfections for good flow characteristics. A pressure tap shall be included on or near the discharge flange.
- B. Inlet Suction Cone:** The inlet suction cone shall be ductile cast iron with all water passages to be smooth, and free of blowholes and imperfections for good flow characteristics. The suction cone shall incorporate a spiral groove to channel fiber into the casing that would otherwise bind between the impeller OD and the inlet cone ID. The clearance of the impeller to the cone shall be externally adjustable without requiring pump or piping disassembly or special tools. A baffle ring will be provided when required to prevent vortexing.
- C. Impeller:** Shall be open channel, screw-centrifugal. The impeller shall be ductile cast iron and shall be dynamically balanced. The single-passage impeller shall combine the action of a positive displacement screw and a single-vane centrifugal impeller.
- D. Backplate Insert Cutter:** Shall be fitted into the back plate behind the impeller, designed to cut against a cutter in the impeller hub, reducing and removing stringy materials from the mechanical seal area. Insert cutters shall be alloy steel heat treat hardened to minimum Rockwell C 60.
- E. Impeller Hub Cutter:** Shall be alloy steel hardened to minimum Rockwell C 60 and fitted into the impeller hub (except 3" model).
- F. Pump Shafting:** Shall be heat treated alloy steel. Upper shaft extension shall be turned, ground and polished. The shaft column shall be minimum 3-1/2" schedule 40 steel pipe welded to steel flanges and machined with piloted bearing fits for concentricity of all components. All support column tubes shall be leak tested. Distance between shaft bearings shall not exceed critical speed dimensions.
- G. Pump Shaft Bearings:** Shall be oil bath lubricated by I.S.O. grade 46 oil, with the exception of the top bearing, which shall be grease packed. The bearings shall have a minimum L-10 life of 100,000 hours. Shaft thrust in both directions shall be taken up by two back-to-back mounted single-row angular contact ball bearings or two face to face mounted tapered roller bearings, with a mechanical seal to isolate the bearings from the pumped media.
- H. Pump Mechanical Seal:** The mechanical seal shall be located immediately behind the impeller hub to maximize the flushing available from the impeller. The seal shall be a cartridge-type mechanical seal with Viton O-rings and silicon carbide (or tungsten carbide) faces. This cartridge seal shall be pre-assembled and pre-tested so that no seal settings or adjustments are required from the installer. Any springs used to push the seal faces together must be shielded from the fluid to be pumped. The cartridge shall also include a 17-4PH, heat-treated seal sleeve and a ductile cast iron seal gland.
- I. Automatic Oil Level Monitor:** Shall be located above the mounting plate and be fitted with an internal oil level switch to monitor oil level and shut off the motor in event of low oil level. A relay shall be included for mounting in the motor control panel.
- J. Shaft Coupling:** Shall be T.B. Woods Sureflex elastomeric type with a minimum 1.5 service factor based on the drive rated horsepower, and shall be protected with a guard meeting OSHA requirements.
- K. Motor Stool:** Shall be a fabricated carbon steel weldment machined with piloted fits to positively align the C-flanged motor and pump shaft, with no adjustments.
- L. Pump Deck Plate:** Shall be fabricated carbon steel, and shall include lifting lugs.
- M. Stainless Steel Nameplate:** Shall be attached to the pump giving the manufacturer's model and serial number, rated capacity, head, speed and all pertinent data.
- N. Motor Requirements:** Drive motor shall be \_\_\_ HP, \_\_\_ RPM, \_\_\_ volts, 3 phase, 60 hertz, 1.15 service factor, TEFC enclosure. The motor shall be sized for non-overloading conditions.
- O. Surface Preparation:** Solvent wash and a single coat of Tnemec 431 epoxy (except motor).
- P. OPTIONAL Premium Surface Preparation:** Solvent wash, sandblast, and coat with minimum 30 MDFT Tnemec Perma-Shield PL Series 431 epoxy (except motor).