

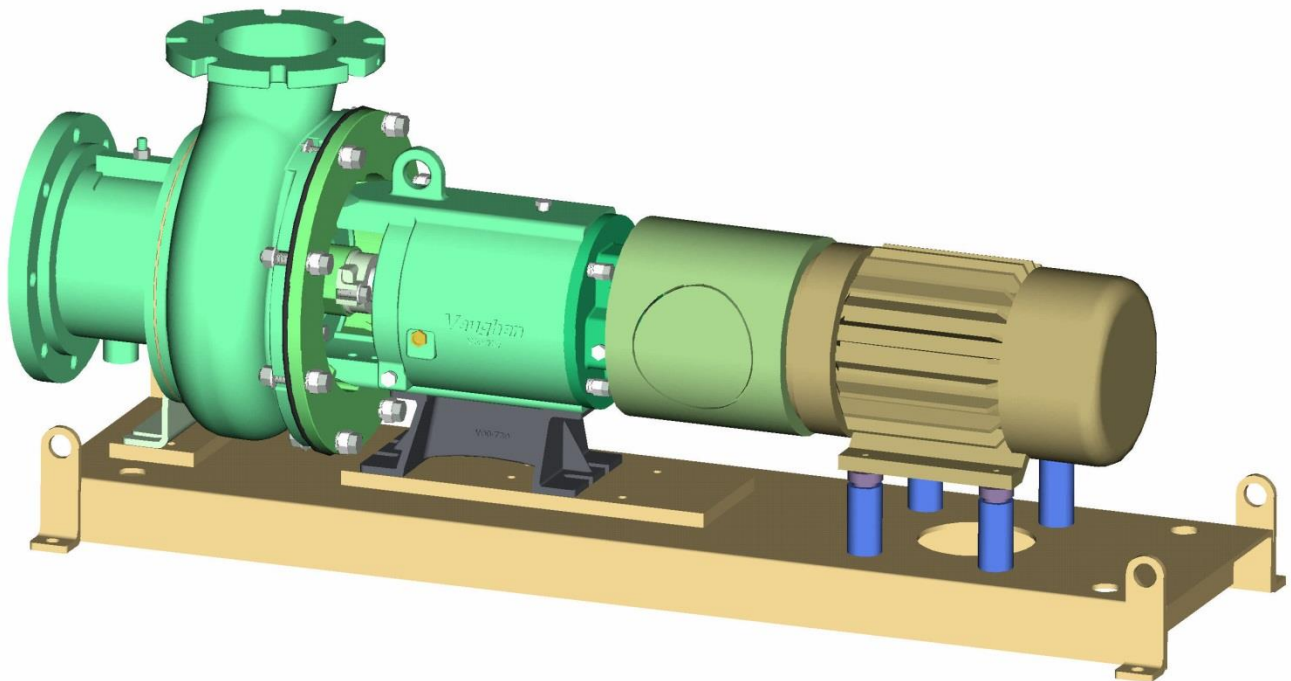

HE SERIES HORIZONTAL CHOPPER PUMPS



INSTALLATION, OPERATION & MAINTENANCE INSTRUCTIONS

VAUGHAN CO., INC.
364 Monte Elma Road, Montesano, WA 98563
Phone: 1-360-249-4042 / Fax: 1-360-249-6155
Toll Free Phone (US only): 1-888-249-CHOP (2467)
Web Site: www.chopperpumps.com
Company E-mail: info@chopperpumps.com



TABLE OF CONTENTS

INSTALLATION, OPERATION, & MAINTENANCE INSTRUCTIONS

1. SAFETY INFORMATION	Page 1
2. DESCRIPTION OF VAUGHAN HORIZONTAL CHOPPER PUMP	Page 3
A. Description of Major Components	
B. Proper Applications for Vaughan Chopper Pumps	
C. Use of Vaughan Pumps that May Cause Trouble	
D. Expected benefits of Vaughan Pumps	
3. INSTALLATION INSTRUCTIONS	Page 7
A. Receipt Inspection	
B. Storage Considerations	
C. Pump Mounting	
D. Piping	
E. Seal Flushing	
F. Motors and Controls	
G. Bearings	
H. Bearing Isolators	
4. STARTUP INSTRUCTIONS	Page 10
5. NORMAL OPERATION OF PUMP	Page 14
A. Noise	
B. Vibration	
6. SHUTDOWN INSTRUCTIONS	Page 14
A. Manual Shutdown1	
B. Automatic Shutdown	
C. Emergency Shutdown	
7. MAINTENANCE	Page 15
A. Routine Maintenance	
B. Corrective Maintenance	
8. TROUBLESHOOTING	Page 18
9. WARRANTY	Page 20

SECTION 1: IMPORTANT SAFETY INFORMATION

IMPORTANT INFORMATION FOR INSTALLERS OF THIS EQUIPMENT!

This equipment is intended for installation by technically qualified personnel. Failure to install it in compliance with national and local electrical codes, building codes and within Vaughan Co. recommendations may result in electrical shock, personal injury or death, fire hazard, unsatisfactory performance, and equipment failure. If further assistance is required contact your local representative or Vaughan Co. *Keep this manual in a safe location for future reference.*



DANGER Indicates a hazard, which, if not avoided, will result in death or serious injury.



WARNING Indicates a hazard, which, if not avoided, could result in death or serious injury.



CAUTION Indicates a hazard, which, if not avoided, may result in minor or moderate injury or damage to the equipment.

NOTICE

Indicates special operation or maintenance information.

- Isolate the pump hydraulically and electrically before servicing or inspecting pump. Lock out both power source and isolation valves.
- This pump may handle dangerous or contaminated fluids. There are sharp corners, edges and pinch areas which can cause serious injury. Be careful; wear protective gloves whenever possible. If you cut yourself, seek medical help immediately to avoid serious infection.
- This pump may start automatically if wired to float switches or other equipment. Before inspecting or making adjustments disconnect electrical power and lock out circuit breakers to pump motor and associated equipment. Duplex pumps with alternating relays must both be locked out; otherwise the pump you are working on may not be isolated and could start as “the alternate”. Visually confirm that the pump has come to a complete stop before proceeding.
- Motors may be equipped with built-in thermal overloads to shut off the motors in the event the temperature gets too high (as a result of low voltage, poor ventilation, overloaded lines, etc.) These motors can restart automatically as the motor cools down. DO NOT work on the pump or motor without first disconnecting and locking out the power supply.
- Enter tanks or pits with extreme caution and only after an instrument check of the pit/tank has been completed to verify the absence of dangerous gases and the presence of safe levels of oxygen. Never enter a tank or pit without a safety harness and lifeline, and an air pack. Never enter the pit without rescue personnel standing by. Follow all national and local requirements for confined space entry.
- Keep all pit openings covered when not in use. In addition to the injuries from falling, pits may contain poisonous gases or liquids.
- The pump is to always be lifted using adequate crane and sling capacity. All applicable safe hoisting practices should be employed. When doing so, rig the load to prevent flipping. Do not use the motor lifting eyes to lift the assembled pump. Use the motor lifting eyes to lift the detached motor only. Cast-in lifting eyes are designed for lifting individual pump components or sub-assemblies, not the entire pump. Only base-mounted lifting eyes may be used to lift a pump and drive assembly.
- Do not allow people under the pump assembly while it is being lifted.
- Pump components can be heavy. Proper methods of lifting must be employed to avoid physical injury and/or equipment damage. Steel toed shoes should be worn at all times.
- Do not allow liquid to be trapped in pump or piping between two closed valves. Always drain or vent the piping/pump between two closed valves. Failure to vent or drain could allow dangerous pressures to build causing rupture damage that may result in injury, death, and equipment damage.
- Never operate a pump with closed or blocked discharge valves. This will destroy the pump and could be dangerous to personnel.
- Make certain all personnel are clear of equipment before operating.

- Safety apparel to be worn when working on or making adjustments to pumps should include:
 - Heavy work gloves when handling parts with sharp edges, especially impellers.
 - Safety glasses (with side shields) for eye protection
 - Steel-toed shoes for foot protection when handling parts, heavy tools, etc.
 - Other personal protective equipment to protect against hazardous/toxic fluids and gases.
- Do not operate this equipment unless safety guards or devices are in place and properly adjusted.
- Let the pump cool to ambient temperature before beginning work on it. A warm pump can contain compartments of pressurized fluid, which may vent violently during disassembly.
- Never apply heat to remove parts unless specifically directed to do so in overhaul instructions. Use of heat may cause an explosion due to trapped fluid, resulting in severe physical injury and property damage.
- Pressure may build up in the standard mechanical seals used in Vaughan pumps. Whenever checking or maintaining the oil in the Vaughan Cartridge Seal, or the welded metal bellows seal with seal oil chamber, make sure the pump and seal are cool to the touch. Use care when removing the oil chamber plugs and pressure relief valve, in case any residual pressure exists. If pressure exists, the plug could become a projectile and/or contaminated oil could spray.
- As it is possible to run Vaughan Chopper and Screw pumps dry, for quality assurance or troubleshooting reasons, it is extremely important to ensure suction and discharge connections are always properly guarded to prevent anything (i.e. foreign objects or pump parts) from being thrown from the pump as a projectile. All pumps must be run with suction and discharge piping in place, or blind flanges installed on suction and discharge connections. Blind flanges should be vented to avoid pressure build-up. Note that cast rotating parts could break if metal to metal contact occurs while the pump is running dry.
- Shut pump off when adjusting fittings to avoid being sprayed with pumpage. Pumped materials may be hot, corrosive, poisonous, infectious, or otherwise dangerous to personnel.
- Pump motors are connected to high voltage. Allow only qualified electricians to service this electrical equipment only in accordance with the latest revision of the National Electrical Code and other applicable requirements.
- This equipment may not meet explosion proof requirements for hazardous environments unless specifically ordered for this purpose. Introducing non-explosion proof equipment into a hazardous environment as defined by the National Electrical Code can cause a dangerous explosion.
- This pump uses oil which, if spilled, can cause a slipping hazard and danger to personnel.
- Keep hands, feet and clothing away from moving machinery.
- Never clean, oil, adjust, or repair machinery while in motion.
- Keep electrical control panel area clear to avoid to avoid hazard to personnel. If a person should trip and fall into an open panel enclosure, serious electrical burns can result.
- Keep electrical control panel doors closed except to make adjustments or repairs by a qualified electrician.
- Overheated pumps can cause severe burns and injury. If overheating of pump casing occurs:
 - Shut down pump immediately.
 - Wait for pump to cool to air temperature.
 - Slowly and cautiously vent pump at drain plug.
 - Trouble shoot cause of overheating.

If there are any questions regarding the safe and proper methods for operating or servicing this pump, please contact Vaughan Company for assistance.

SECTION 2: DESCRIPTION OF HE-SERIES HORIZONTAL CHOPPER PUMPS

The Vaughan end-suction horizontal chopper pump is specifically designed for pumping debris-laden liquid slurries. Debris is chopped by the pump impeller slicing against it at the suction cutter bar as it enters the pump, so that particle size is reduced and down-stream plugging problems are greatly reduced. In this way the pump impeller serves a dual function of both pumping and chopping.

The HE Series chopper pumps also offer these additional design features:

- 1) The back pullout casing design allows for easy removal of the rotating assembly without disconnecting suction or discharge piping.
- 2) The impeller-to-cutter bar and impeller-to-upper cutter clearances are externally adjustable.
- 3) Vaughan flushless cartridge seal is standard and has the additional advantage of being fully covered by the Vaughan warranty.

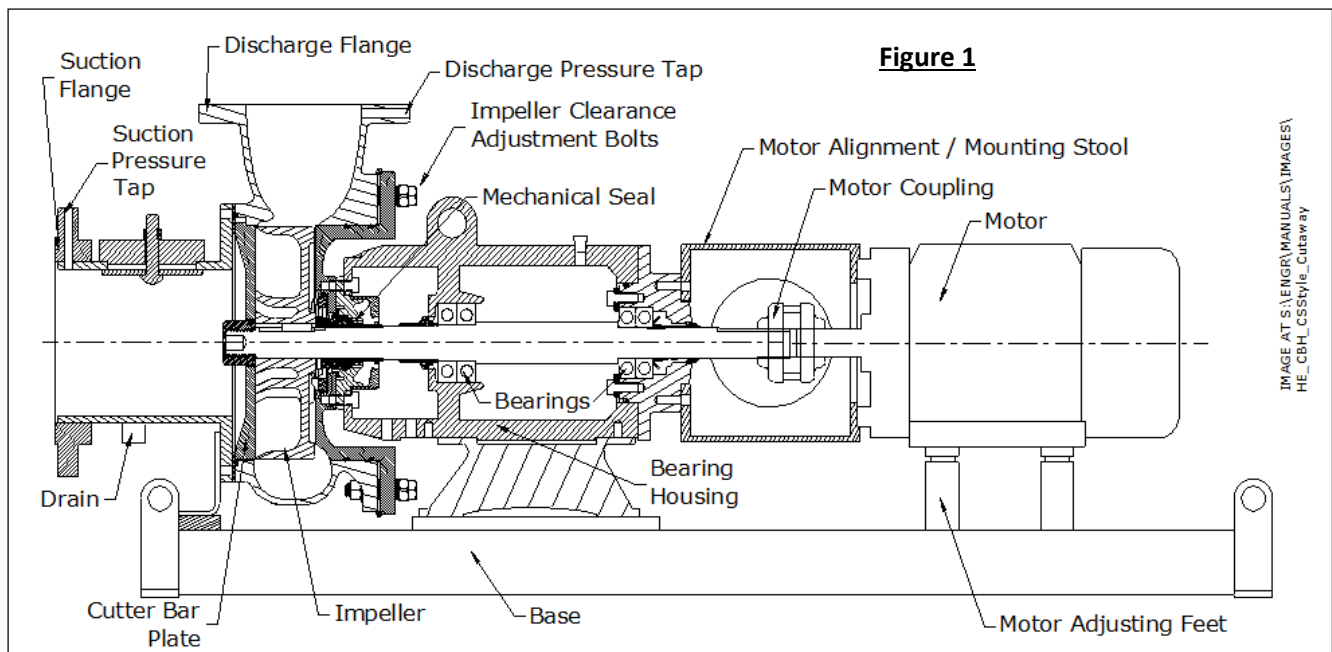

A. DESCRIPTION OF MAJOR COMPONENTS

CHOPPER IMPELLER

The impeller on the Vaughan pump serves two purposes. It induces flow by propelling liquid material through the pump casing, and also chops solids by slicing against the cutter bar. The leading edge of each impeller blade is sloped forward to create a knife edge. As material enters the pump, it is caught and cut between the knife edges on the impeller blades and the stationary bars of the cutter bar. The standard impeller is made of cast alloy steel and is heat treated to Rockwell 60C.

CUTTER BAR

The cutter bar is a patented design that serves two functions. First, it serves the function of a “suction plate”, sealing the intake of the pump. The pressure generated by the impeller is kept inside the pump by the close clearances between the cutter bar and the impeller. Second, the cutter bar includes two shear bars which span the entrance to the pump. Material is chopped by the pump impeller cutting against these stationary shear bars. The standard cutter bar is made of alloy steel and is heat treated to Rockwell C60.

CUTTER NUT

The cutter nut is a patented design that serves two purposes. First it secures the impeller to the shaft. Second the raised cutter tooth design prevents pump binding by cutting stringy materials that could otherwise wrap around the shaft and block the intake opening. The cutter nut is made of cast alloy steel heat treated to Rockwell C60. All 3-6" chopper pumps have a cutter nut.

EXTERNAL CUTTER (OPTIONAL ON 3-6" PUMPS)

The external cutter has opposing cutter wings that shear against the outside face of the cutter bar. It is used to prevent binding or the buildup of string materials at the pump inlet. The external cutter is made of cast alloy steel, heat treated to Rockwell C60. Chopper pumps 8" and larger will have an external cutter.

UPPER CUTTER

The upper cutter is located behind the impeller and cuts against the pumpout vanes and the impeller hub to for the purpose of preventing stringy materials from wrapping in the mechanical seal area. The upper cutter is made of alloy steel heat treated to Rockwell C60.

MOTOR MOUNTING

Vaughan horizontal End-Suction pumps are usually directly driven by C-Face electric motors through a TB Woods Sure-Flex elastomeric coupling. The motors are rigidly mounted to the pump bearing housing by a machined and piloted motor stool. This piloted mounting ensures proper motor and pump shaft alignment without requiring special alignment of the motor and pump shafts at your plant. If your pump is belt-driven, it will either have the motor mounted to the side of the pump or overhead, depending on how it was ordered. Belt driven pumps have arrangements for motor movement to adjust the belt tension. It is advisable to use flexible conduit to the motor so that the motor can move with the rotating assembly for adjustment or service to the wetted parts of the pump.

FLUSHLESS MECHANICAL SEAL (Vaughan Cartridge Seal, STANDARD)

The HE Series End-Suction Chopper Pump is usually supplied with a Vaughan flushless, cartridge-type mechanical seal placed directly behind the impeller, shown below in Figure 2. **This seal will not require any water flush to keep it clean.** The only maintenance required of the Vaughan Cartridge Seal is a yearly change of the oil. There are three pipe plugs located on the outboard end of the seal to drain and refill the oil (see Figure 3 below). For 3"-6" and 8K pumps, use 2 oz. and for 8"-16" pumps, use 6 oz. of ISO 46 oil to refill. This will fill the seal approximately 1/3 full, which is correct.

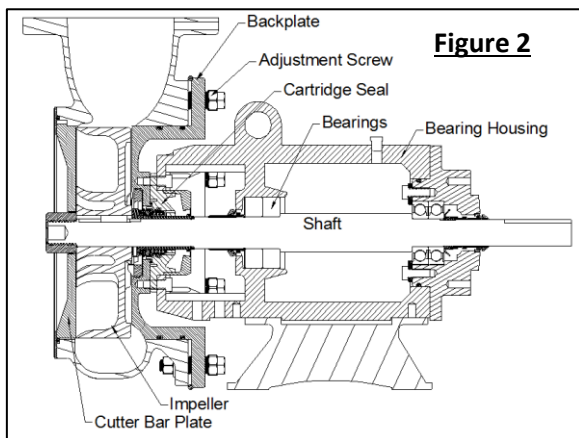

Figure 2

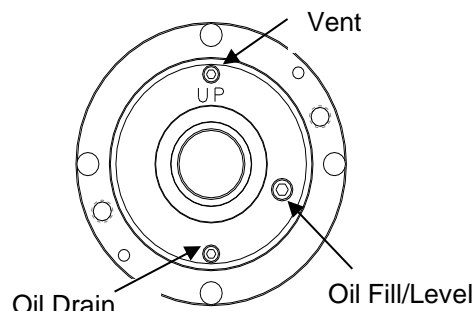

Figure 3

VAUGHAN FLUSHLESS CARTRIDGE SEAL

NOTICE

If it is ever necessary to remove the cartridge seal assembly from the pump, you must first install the seal cartridge cap. This cap is a separate component, used during installation, which holds all of the seal components together. If you do not have this cartridge cap contact Vaughan Co.

MECHANICAL SEAL (Metal bellows type, NON-STANDARD)

The HE series End-Suction Chopper pump may also be supplied with a welded bellows mechanical seal with silicon carbide faces. Always flush the seal chamber with 6-10 GPH of water from a seal flush system pressurized to at least 10 psi above the pump discharge pressure. A flow control device, such as a Rotameter, should always be used to throttle the flow to 6-10 GPH. (Too much flow and pressure can erode the insides of the stuffing box.) Figure 6 on page 12 shows the recommended seal flush installation.

OPTIONAL WELDED BELLOWS SEAL

Figure 4

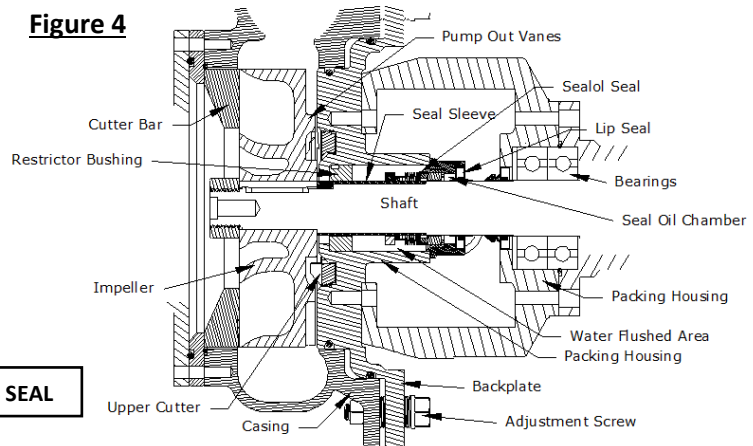

CAUTION

Pressure may build up in the mechanical seals used in Vaughan pumps. Whenever checking or maintaining the oil in the Vaughan cartridge seal, or the welded metal bellows seal with seal oil chamber, make sure the pump and seal are cool to the touch. Use care when removing the oil chamber plugs, in case any residual pressure exists. If pressure exists, the plug could become a projectile and/or contaminated oil could spray.

PACKING (NON-STANDARD)

If your pump was ordered with packing, the packing is typically TFE impregnated graphite packing with reinforced Kevlar corners. The lantern ring is split for easy removal and made from glass-filled TFE. All packing components run on a nickel chrome boron coated 316 stainless steel shaft sleeve. Packing should always be water flushed with the flush line interlocked with the motor starter so that flush water begins when the motor starts. Supply flush water at a pressure of about 10 psi above pump discharge pressure. Your pump has shipped with the packing gland bolts finger tight for initial break-in period of the packing. The following steps are required for proper break-in.

1. Before flooding the suction or starting the pump, turn on the flush water. If the water is leaking excessively from the stuffing box it is OK to tighten the bolts on the packing gland. Only tighten the bolts one flat at a time. Reduce flow only to the point where it is containable inside the packing housing drain.
2. Flood the pump suction and start the pump.
3. Flush water will be freely leaking from the stuffing box. Tighten the bolts on the gland one flat at a time every five to ten minutes until **the leakage rate is 17 - 30 drops per minute for 3"-6" & 8K pumps and 35 - 50 drops per minute for 8"-16" pumps.**

Tightening the packing gland bolts by as little as a 1/4 turn can be enough to change the leakage rate when the assembly is close to the desired leak rate. This procedure could take a few hours.

The break in procedure is now complete. As your pump runs continue to monitor and adjust the packing gland as required to maintain proper leakage.

Figure 5

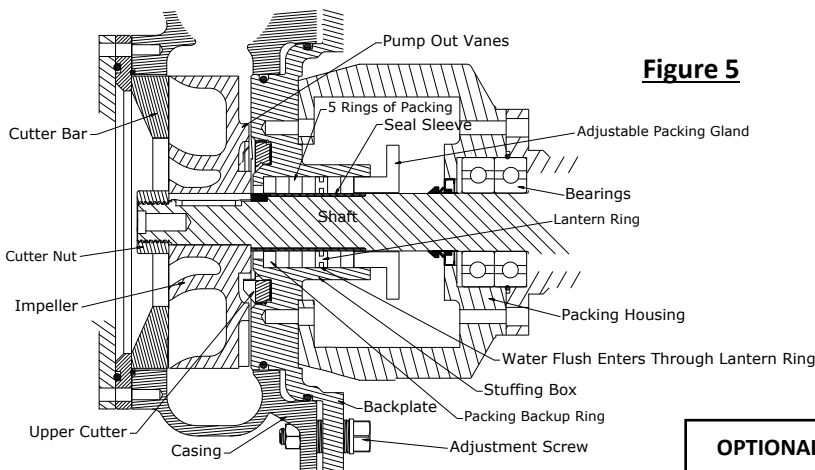

OPTIONAL PACKING ARRANGEMENT

FOR VAUGHAN CHOPPER PUMPS

B. PROPER APPLICATIONS

Vaughan Chopper Pumps are used for pumping liquid slurries contaminated with debris which can be chopped and mixed into the slurry. The benefit of chopping the pumpage is that a more homogenous slurry is pumped, making some slurries pumpable that would normally not be, and eliminating downstream plugging in piping and other equipment. Screens located upstream of the pump may often be eliminated, which will cut labor costs. Vaughan pumps are routinely used to pump the following slurries:

1. Sewage and sewage sludge
2. Fish waste.
3. Vegetable waste.
4. Mill scale.
5. Aluminum chips from machining operations.
6. Lead oxide and plastics in battery plants.
7. Oil sludges in oil refineries.
8. Wood chips and paper waste.
9. Animal manures (dairy cow, pigs, and chicken).
10. Feathers mixed with blood and water in poultry plants.
11. Animal fat in rendering and hide processing plants.
12. Plastic debris.
13. Coal slurry.

System design is very important in making any pump work successfully in debris-laden slurries. There must be enough liquid so that liquid and material are able to flow freely to the pump. The piping must be properly designed to be large enough to reduce friction losses, yet small enough to ensure sufficient velocity to keep particles suspended.

C. USES OF VAUGHAN PUMPS THAT MAY CAUSE TROUBLE

If the system is not designed correctly for proper handling of your material, or if the pump is incorrectly chosen for your system, the pump may not work to your satisfaction or the pump may experience early failures of seals or bearings due to cavitation and the resulting vibration. Vibration will damage mechanical seals and bearings fairly quickly. Common rules of thumb include:

1. A pump must be operated in the acceptable (solid) portion of its pump performance curve. Operation in the dashed lines indicates vibration areas. Pump damage will occur if operated in these extreme low-flow or high-flow parts of the pump curve.
2. Chopper pump impellers with the largest number of blades are the most efficient, but they also provide the poorest solids handling. Added impeller blades block the inlet and cause increased binding on fiber during chopping. When pumping sewage and similar slurries, choose impellers with the *least* number of blades.
3. When pumping materials that float or settle in a pit, mixing and chopping with the pump may be required before pit pump out. This can be done by initially directing the discharge back into the pit. This will alleviate buildup of solids in the pit.
4. Slurry that is too hot cannot be pumped from an open pit. A reasonable limit at 1170 RPM is about 180° F, at 1750 RPM it's about 160° F.
5. A reliable and properly sized electrical supply must be installed for the pump to work properly. If there is too much voltage drop because of an undersized cable or transformer, the motor will not be able to provide full power to the pump and it will stall during chopping of debris.

D. EXPECTED BENEFITS OF VAUGHAN PUMPS

Most customers who install a Vaughan pump see several advantages:

1. Minimal pump attention is required.
2. Chances of pump plugging or binding on tough solid or fibers are minimized.
3. Minimal plugging problems downstream, because the material is preconditioned.
4. Elimination of ancillary grinders or comminutors upstream of the pump.
5. Long and reliable life of the Vaughan pump.

SECTION 3: INSTALLATION INSTRUCTIONS

A. RECEIPT INSPECTION

Prior to shipment Vaughan pumps are carefully crated and inspected to ensure arrival at your plant in good condition. On receiving your pump, examine it carefully to assure that no damaged or broken parts have resulted from mishandling during shipping. Turn the pump shaft by hand and verify that it turns over smoothly. If the shaft binds, look for debris (or paint) between impeller and cutter bar. Otherwise, shaft binding could indicate damage. If damage has occurred, report to your carrier immediately, and consult your local Vaughan representative.

B. STORAGE CONSIDERATIONS

If equipment is to be stored for longer than two weeks, take the following action:

- 1) Coat exposed steel with a light layer of grease to protect the equipment from corrosion.
- 2) Rotate the motor 1-1/4 turn once each week to keep the bearings from sitting in one position for extended periods of time.
- 3) Avoid storing rotating equipment near other vibrating equipment. The vibrations can cause damage to the bearings and cause premature failure once the equipment is started up.
- 4) Store rotating equipment in a clean, dry, heated area away from areas where it could be damaged from impact, smoke, dirt, vibration, corrosive fumes or liquids, or from condensation inside the motor or pump. It is helpful to cover equipment with plastic.

C. PUMP MOUNTING

Vaughan pumps are heavy and will require a crane to lift into position. Lifting the pump by the lifting lugs at the base is always a safe method for lifting. Do not lift by the motor eye.

⚠ WARNING

The pump is to always be lifted using adequate crane and sling capacity. All applicable safe hoisting practices should be employed. When doing so, rig the load to prevent flipping. Do not use the motor lifting eye to lift the assembled pump. Use the motor lifting eye to lift the detached motor only. Cast-in lifting eyes are designed for lifting individual pump components or sub-assemblies, not the entire pump. Only base-mounted lifting eyes may be used to lift a pump and drive assembly. Do not allow people under Vaughan equipment during hoisting operations. Consult the Vaughan Co. shipping department for weight of your equipment if you are in doubt.

Anchors

Vaughan pumps should be securely bolted to a level, flat floor or slab with stainless steel anchors to minimize operational vibrations. Expansion-type, cast-in place J-bolts, bolts mounted in sleeves, and epoxy anchoring systems are all acceptable anchoring means.

Leveling the Base

Vaughan Co. assembles and aligns the completed pump and motor assembly on a level surface at the factory and runs the pump at speed to measure dry-run vibration levels and to ensure that no metal-to-metal contact occurs. If the base is not mounted to a level, flat surface in your installation, twisting of the base and pump could occur that can cause metal-to-metal hitting of the cutting parts during operation. Careful shimming is required to properly align the suction piping to the pump and to ensure that the pump base is level (not twisted) and properly aligned to the suction piping. As the pump is shimmed, turn the pump shaft over by hand to ensure that no metal-to-metal contact is occurring. If metal-to-metal contact is discovered during pump startup and actual pumping, additional shimming may be required to take additional twist out of the base and pump. Do not completely tighten the anchors until grouting is completed and is properly hardened. Note that this pump is expected to be mounted horizontally with no more than 0.2" rise per foot (+/- 1° of level). If mounted at an angle, both sets of bearings may not receive adequate oil lubrication. If this cannot be accomplished consult factory for other options.

Grouting

Vaughan Co. recommends that all horizontal pumps be grouted in place. Standard horizontal baseplates include grout holes and vents to facilitate grouting. The purpose of grouting is to prevent shifting of the baseplate, to reduce vibrations (by increasing mass), and to fill in irregularities in the foundation. A typical mixture for grout is one part Portland cement and two parts building sand combined with enough water to allow grout to flow under the base. Wet the concrete foundation before grouting the pump in place. A wooden form is needed around the pump base to retain the grout. Add grout until the entire underside of the pump base is filled, working air out with a stiff wire or rod through the grout holes. Cover the exposed grout with wet cloth or burlap to prevent cracking during setup. Remove the wooden forms once the grout is setup and then smoothly finish the exposed surfaces. Fully tighten the anchors only after the grout is completely hardened. Shims used for leveling and alignment may be left in place.

Direct-Drive Motor Adjusters

Horizontal direct-drive pumps use a machined motor stool aligned to the motor C-Face end bell so that pump/motor coupling alignment is assured. Threaded adjustable motor supports are provided under each of the motor feet that are designed to just touch the pump base when aligned at the factory. The adjusters are held in place by a set-screw. After shimming and grouting the base, loosen each motor adjuster set-screw and reset the adjusters so that they just touch the base, then re-tighten the set-screw.

Belt-Drive Adjustments

Belt-drive pumps have been aligned and tensioned at the factory, **but the belts are loosened before shipping**. You will need to properly re-adjust the belt tension and alignment following the instructions in Section 4 of this manual. Belts that are too tight can cause premature belt or bearing failures, belts that are too loose may experience belt slipping and belt failure.

D. PIPING

NOTICE

Never use force to draw piping to pump flange. Excess forces on the pump will reduce seal and bearing life. Be sure all piping connections are tightened and properly supported before operation.

Be sure that the weight of piping connected to the pump suction and discharge flanges is properly supported. Do not expect the pump to support your piping system, as this may cause large stresses on the pump and may cause metal-to-metal interference problems during actual pump operation due to distortion of the pump or base. These stresses can result in a broken or cracked casing or premature bearing and seal failures, as well. Before bolting up piping to the pump, make sure that flanges are closely aligned.

Great care should be taken with suction piping on horizontal pumps to avoid restricting flow to the pump. Avoid bends and fittings and keep suction piping as short as possible and as large as possible. *Suction piping must be as large as or larger than the pump suction flange.* Long and restrictive runs of suction piping can contribute to gas binding problems, especially in scum and sludge transfer applications. Never install a check valve in the suction piping.

Remember that sludges have significantly higher friction losses than water, so larger diameter piping is always helpful when pumping this material. Maintaining suction velocity below 8 feet per second is helpful. If you are pumping uphill or into a force main, or if there is more than one pump pumping into a common header, a check valve and an isolation valve will be required on the discharge of the pump. Note that Vaughan pumps have pressure taps on the suction and discharge flanges for installation of pressure gauges for testing purposes, particularly important at pump startup. See Vaughan Recommended Piping Practices, Form V435 for additional information.

E. SEAL FLUSHING (FOR OPTIONAL METAL BELLOWS SEALS)

The standard mechanical seal used in Vaughan pumps since 2003 is the Vaughan flushless cartridge seal, designated "CS" in the pump model. This seal requires no external flush and is cooled and lubricated by the oil chamber that is part of the seal assembly. Other mechanical seals may be installed in your pump if it was specified this way. Seals other than the Vaughan flushless seal must be flushed with at least 6-10 gallons per hour of clean water. There is a 1/8" NPT fitting on the stuffing box for this purpose. The seal water must be supplied at a pressure at least 10 PSI above the pump discharge pressure, and regulated with a flow meter to the proper flow of 6-10 GPH. A solenoid valve must be installed to switch the water on and off with the pump motor. A schematic of this system is shown at right.

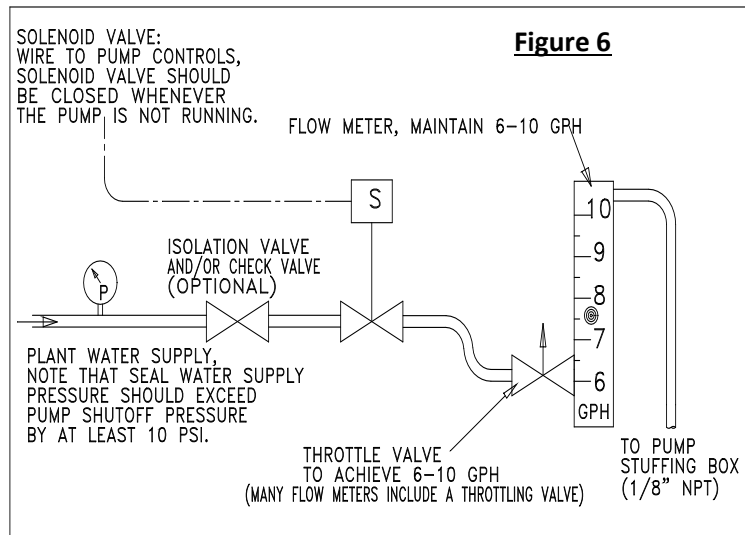

F. MOTORS AND CONTROLS

Most motors provided on Vaughan pumps are TEFC C-Face and are not designed for hazardous environments or rated as explosion proof. However, some applications require explosion-proof motors. If your pump is located in a hazardous location, be sure you ordered and received your pump with an explosion-proof motor and that you use an electrician experienced in hazardous environment wiring and controls.

Vaughan Chopper Pumps, because they cut and condition the material they pump, require motor protection with correctly sized breakers, starters, and overload protection. A Chopper Pump can jam and stall on material too tough to chop, such as steel rebar. Therefore, carefully chosen overload protection for your expensive motor is critical to avoid motor burnout. Note that nuisance tripping during chopping can occur if you do not have an adequately sized circuit breaker. The circuit breaker should never open during chopping, only during a short circuit. High current trip settings for Starters and VFD's should be set at 110% of motor nameplate full load current to prevent the current spikes from tripping out those devices while chopping.

Selecting a motor with a base speed at the upper end of your operating range and slowing it down to hit the low range results in lowest available torque and may not be recommended. *Note, when slowing a motor down below nameplate speed with a VFD it is very important to remember that available horsepower drops in direct proportion to speed reduction, so a 100 HP motor running at 30 Hz can only make 50 HP max at 30 Hz.*

Selecting a motor with a base speed at the lower end of your operating range and speeding it up to hit the high range results in the highest available torque and is generally preferred for chopper pump applications. *When speeding a motor up above nameplate speed, available horsepower = nameplate horsepower.*

Minimum allowable speed for Rotamix applications is 75% of base speed. Minimum allowable speed for other applications is dependent on system curve, and is the speed required to maintain minimum allowable flow per our published curves. Consult Vaughan Co. for assistance if needed.

Severe duty applications like septage receiving, screenings, beef processing, or any application with an external cutter often require oversizing the motor to get sufficient torque. Oversizing the motor has the added benefit of increasing rotational inertia to help carry the impeller through each chop.

When driving chopper pump motors with a VFD, it is important that Constant Torque type VFD's be specified. Constant torque VFD's allow for maximum chopping torque at all speeds. (Variable Torque units have reduced torque and horsepower at reduced speeds)

As discussed earlier, it is a good idea to run flexible conduit to the motor to facilitate the back pullout advantages of this pump.

G. HORIZONTAL BEARING SYSTEM

Horizontal Chopper pumps have oil-bath bearing lubrication. The proper oil is ISO 46 hydraulic oil. Oil level is indicated by a sight glass mounted on the side of the bearing housing. The oil level is correct when oil is in the center of the sight glass. Overfilling the bearing housing can cause heating and oil spillage. The pump must be mounted horizontally.

Vaughan Co. uses Chevron Rando HD-46 which is ISO 46 hydraulic oil. The following oils have the viscosity and rust inhibiting additives to make them excellent alternates for the Rando HD 46: Chevron GST 46, Chevron EP 46, Exxon Terissic 46, Shell Turbo 46 and Texaco Regal 46. Most ISO 46 hydraulic oils and ISO 46 turbine oils should be compatible with Rando HD 46 supplied in our pumps.

BEARING ISOLATORS

Bronze non-contacting labyrinth style, O-ring mount bearing isolators are provided at each end of the bearing housing. The bearing isolators provide maintenance free, permanent bearing protection by keeping the oil in the bearing housing while blocking outside contaminants from entering. Oil captured in the labyrinth flows back into the bearing housing, while outside contaminants are expelled through a port in the stator.

SECTION 4: PUMP STARTUP INSTRUCTIONS

NOTICE

Review safety information in Section 1 of this manual before proceeding.

- 1) All directly-driven Vaughan pumps using C-Flange electric motors are designed and built for automatic alignment of motor and pump shafts during assembly. Four motor adjusters have been supplied with your pump. Tighten them just enough to support the weight of the motor but no more.
- 2) Belt-driven pumps have shipped with the belts de-tensioned and the belts will need to be tightened before startup. Vaughan's bill of material (BOM) for your particular pump and belt-drive system lists the belt tension required by the drive manufacturer. After the pump is installed, plumbed, and bolted down into final position follow the procedure below to tighten the belts to the tension noted on the pump BOM.

WARNING

Lock out power source before tensioning belts. Replace belt guard before applying power to the pump.

- a. Remove the belt guard outer cover and set it aside. Loosen the motor hold down bolts and turn the belt tensioning bolts under motor until belts are tight and can be depressed approximately $\frac{1}{2}$ " in the center of one belt by hand.
- b. Place a steel straight edge across the two belt sheave's centers, passing directly over the center of the shafts. If the two sheaves are in alignment, the straight edge will touch each edge of each sheave. If the straight edge doesn't touch in four places, move the motor with the adjusting screws (and perhaps axially if necessary) to obtain a perfect four point match. Close is not acceptable. Even a small misalignment can cause vibration and premature belt/sheave wear. You may need to push on the back side of the motor with the adjusting screw. The screw will push if it is threaded out about $\frac{3}{4}$ ".

- c. Once the sheaves are in proper alignment, the belt tension must be set. During tensioning, move the motor carefully so you don't change the sheave alignment. To check the tension, press in the center of one belt length with a special belt tensioning tool (Vaughan #V800-860) for single belt; (Vaughan #V800-861) for banded belt. For banded belt, the total force will be lbs per rib/strand times the number of rib/strand in the belt. It is very important to set the tension correctly. See the bill of materials for the correct tension.
- d. The alignment/tensioning may have to be repeated until both tension and alignment are correct, as setting one changes the other. These also can change when the motor hold down bolts are tightened. Once the tension and alignment are correct with all bolts tight, reinstall the belt cover.

Figure 7

- 3) The red oil containment cups for both inboard & outboard bearing isolators should be removed before pump startup. No damage to the pump will occur if these are left on by accident, but they will require more power to drive because of added friction. These can simply be cut to remove from shaft.

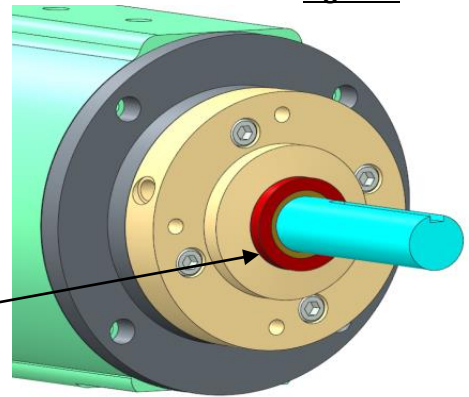

Red oil containment cup for shipping and handling. Remove before pump operation.

- 4) Perform a pump rotation check to ensure Clockwise rotation (as viewed from the motor end) before startup. At the control panel, hit the "ON" button, then the "OFF" button as fast as possible to "jog" the motor at a slow rate. If the motor turns clockwise, you are ready to start the pump. If the motor turns counterclockwise, (wrong direction), then following your plants established lockout/tagout procedures open the circuit breakers to the motor panel, and reverse any two leads on the motor starter in the control panel. Close the breakers to the panel and recheck the motor direction to be sure it's correct.

NOTICE

If the pump is allowed to run backwards for any significant length of time, the impeller can loosen, and eventually damage the pump.

- 5) Review the start-up and certification checklist in this manual, open suction and discharge isolation valves, confirm suction is flooded, and start the pump.

CAUTION

Never operate a pump with closed or blocked discharge valves. This will destroy the pump and could be dangerous to personnel.

- 6) The startup instructions are incorporated into the Startup And Certification Checklist. When the Startup And Certification Checklist is completed please send a copy of the completed checklist to Vaughan Co. Engineering. We will verify that the pump and system are properly matched to protect your investment and our reputation.

NOTICE

Pump speeds and operating conditions must fall within the acceptable limits of the performance curve of the pump. Do not operate in the dashed portions of the curve



Date: _____

PROJECT NAME: _____ LOCATION: _____

PUMP S/N: _____ EQUIPMENT ID/TAG#: _____

STARTUP PERFORMED BY: _____

CUSTOMER CONTACT INFO _____

CONTRACTOR CONTACT INFO _____

ENGINEER CONTACT INFO _____

VAUGHAN HORIZONTAL CHOPPER PUMP STARTUP AND CERTIFICATION CHECKLIST

- Pump is turning CW as viewed from the motor end? Yes _____ No _____
- Motor adjusters are snug to base and set screws tight? Yes _____ No _____
- Pump Shaft turns freely by hand? Yes _____ No _____
- All guards are in place? Yes _____ No _____
- Is the oil level in the middle of the range of the site glass? Yes _____ No _____
- Is the vent in the top bearing housing plug open? Yes _____ No _____
- Is the pump casing vented and filled with liquid? Yes _____ No _____
- Are both suction and discharge valves open? Yes _____ No _____
- All piping attached to pump is being independently supported? Yes _____ No _____
- All piping joints are leak tight? Yes _____ No _____
- Is an air release valve (ARV) installed in the discharge piping? Yes _____ No _____
- If yes, is ARV located in high point before first check valve? Yes _____ No _____
- Flexible joint is connected to pump discharge? Yes _____ No _____
- If yes, is piping anchored between expansion joint and pump discharge, per H.I. standards? Yes _____ No _____
- Construction debris in sump or piping? Yes _____ No _____
- Does Inflow splash down into sump? Yes _____ No _____

ELECTRICAL DATA

Motor Mfr: _____

Motor S/N _____

Motor HP: _____

Motor RPM: _____

Nameplate Voltage: _____

Nameplate F.L. Amperage: _____

Operating Voltage: L1 – L2 _____ L2 – L3: _____ L1 – L3: _____

Operating Amperage: L1: _____ L2: _____ L3: _____

SYSTEM DATA

What type of material are you pumping? _____

Temperature (F°): _____ Specific Gravity: _____ %Solids: _____

Pipe size (inch): _____ Total equivalent length of pipe: _____ feet

Elevation change from water level to discharge point _____ feet

Estimated Total Head (feet): _____ Design Flow (GPM): _____

PUMP OPERATING DATA

Pump Model: _____ Impeller Diameter: _____

Discharge Pressure (fill in psi): **Pump Off (psi):** _____ **Pump On (psi):** _____

Dim "Z1" (distance from liquid level to pressure gauge-feet): _____

Suction Pressure (fill in psi or in. Hg in negative): **Pump Off (psi):** _____ **Pump On (psi):** _____

Dim "Z2" (vertical distance between gauges-feet): _____

Observed Pump Flow (GPM): _____

Pump Speed: _____

Pump is running Quietly _____ Noisily _____ Very Noisily _____

NOTE: If pump is not running quietly, please contact us immediately for help. Severe vibration can damage the pump very quickly.

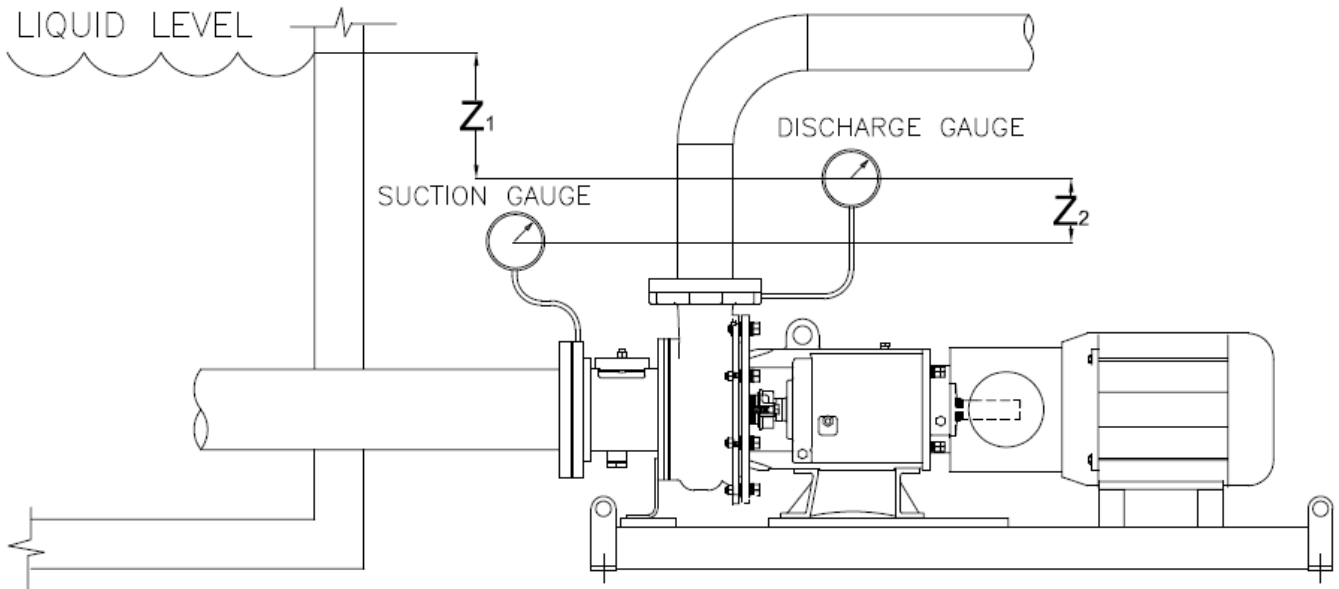

HE START UP DWG. #120227 REV. 0 12/21/18

SECTION 5: NORMAL OPERATION

A. NOISE

Most Vaughan pumps operate at either 1170 or 1750 RPM. At these speeds, the pump is normally quiet running, and the major source of noise is the electric motor. (Higher horsepower, higher head pumps, of course, are noisier.) Sometimes at startup a tank may be full of debris, and the pump will be fairly noisy due to chopping it. This noise should dissipate as the debris is broken up and/or pumped out.

Note that 3510 RPM pumps will be somewhat noisier. At this speed, the normal operating noise will be fairly high (85-90 dbA). Much of this noise will be from the motor fan, but there will be some hydraulic noise. Pay particular attention to the pump casing noise on all pumps. If there are any crackling noises coming from the pump casing, (as if pumping marbles) this could be evidence of cavitation. If these noises persist, please call Vaughan Company to discuss. Cavitation can damage a pump in a very short time period.

B. VIBRATION

Vibration, like noise, should be minimal in the pump unless the pump is doing heavy chopping. If a particularly tough rag, or nylon pantyhose gets caught in the pump, temporary dynamic imbalance and some flow blockage will occur until the rag is chopped up and cleared. These conditions will create an unbalance and vibration. This condition is generally short-lived, and the chopping action of the pump normally clears the obstruction in a short time.

Please note that every effort has been made at the factory to ensure that these pumps operate smoothly and within Hydraulic Institute Standard vibration limits. All impellers are dynamically balanced after impeller machining to 1 mil. or less of imbalance. The pump shaft is fully machined to be straight and is tightly held by bearings so that there is virtually no shaft movement. Your pump should not exhibit any significant vibration or noise in normal operation. If you feel that the pump is noisy or vibrating more than it should, please call Vaughan Company immediately to discuss. Excessive vibration and/or noise may be indicative of system mismatch or other problem that could severely shorten the life of your pump.

SECTION 6: SHUTDOWN INSTRUCTIONS

A. MANUAL SHUTDOWN

In the manual mode of operation, a Vaughan pump is shut down by pushing the "off" button or turning the auto/man/off switch to the "off" position on the front of your control panel. If any repair or maintenance work is to be done on the pump, be sure to follow all the warnings at the beginning of this manual.

B. AUTOMATIC SHUTDOWN

Automatic operation will normally shut the pump down, usually on low pit level. If the pump does not shut down when the pit is empty, the pump may be shut down manually, but you should troubleshoot your level control system to find out why the automatic operation is not working properly. Continued operation of the pump during "snoring" will damage the pump. "Snoring" is a condition where the pump is operating while alternately drawing water and air. The differing loads on the impeller shaft cause high stresses and vibrations that can quickly result in damage.

If you are going to inspect, adjust, or do any maintenance, on the pump or motor, be sure to follow all warnings in this manual, and your plants safety procedures. Be certain to turn off electrical power by opening and locking out the main panel breaker to isolate the pump. Since in the automatic mode, the pump could start without warning if not isolated.

C. EMERGENCY SHUTDOWN

In any kind of emergency when the pump needs to be shut down, operate the manual off switch or push button on the front of the pump control panel. If any work has to be done on the pump or motor, open the main breaker on the pump control panel so that the pump cannot automatically restart when personnel are near the pump or motor. Be sure to lock out the breaker to avoid accidental energization of the pump.

SECTION 7: MAINTENANCE

A. ROUTINE MAINTENANCE

WARNING

Isolate the pump hydraulically and electrically before servicing or inspecting the pump. Lock out both power source and isolation valves. Never clean oil, adjust, or repair machinery while in motion.

MONTHLY:

1. Check amperage draw to the pump motor and compare to amperage measured at startup. Make sure that amp draw does not exceed allowable amperage to the motor at full load.
2. Check for seal or packing leakage at the stuffing box area.
 - a. **Vaughan cartridge seal:** If leakage is observed at the pressure relief valve change oil as described on page 17 of this manual.
 - b. **Metal Bellows Seal:** If seal leakage is evident, the seal faces can be cleaned (metal bellows seals only). Isolate the pump hydraulically and electrically, (See all warnings at front of manual!) drain intake manifold, remove the 2 bolts on the seal gland, and pull the gland back on the shaft to clean the seal faces. Use isopropyl alcohol for the cleaner. If cleaning the seal faces does not stop severe leakage, consult the Vaughan Overhaul Manual for instructions on how to replace the mechanical seal.
 - c. **Packing:** Adjust packing leakage as directed in Section 2 of this manual.

QUARTERLY:

1. Motor: Inspect electric motor. Make sure that motor drain is not plugged with debris. Clean cooling fins so that dirt buildup will not affect cooling ability of motor. Check for loose or corroded hardware and damaged wiring or conduit.
2. Pump: Inspect pump for loose hardware. Make sure that pump is operating smoothly without vibration or cavitation.
3. Check oil level in pump bearing housing and check for oil contamination.
4. Grease motor bearings with bearing grease as specified by the manufacturer
5. Perform monthly inspection as shown above.

ANNUALLY:

1. Check clearances between impeller and cutting surfaces.

Isolate the pump electrically (open & lockout breakers) to make sure that the motor can't start accidentally and adjust the clearance between impeller and cutting surfaces. This can be done without any pump disassembly. Remove a motor stool cover and rotate the coupling by hand. Feel for bearing roughness or cutter contact. If the bearings are rough consider overhauling the pump to change bearings. There are two sets of external adjusters, one set for the impeller/cutterbar gap, and one for the impeller/upper cutter gap. (Refer to the illustration on page 21)

Impeller-Upper Cutter Adjustment

Adjust the clearance between the back side of the impeller and the upper cutter before adjusting impeller to cutter bar clearance. Please follow the procedures closely. It is important to note that if the adjustment sleeves are turned the wrong way, interference will be felt as described but it will be interference on the cutter bar side of the impeller instead of the upper cutter side. This will cause a confusing problem during the next step when the front clearances are adjusted.

- a) Remove a motor stool cover to gain access to the motor coupling. This will allow you to rotate the pump shaft by hand to check for contact between the impeller and cutting surfaces. Roll the shaft over by hand and observe how it feels before you have made any adjustments.

Before beginning to make adjustments, witness mark the adjustment sleeves to help you keep track of how far the adjustment sleeves have been rotated.

- b) Loosen each of the four clamp bolts on the bearing housing cap about $\frac{1}{2}$ turn. Be careful to prevent the adjusting sleeves from turning with the clamp bolts. This is usually performed with two wrenches, one holding the adjuster stationary and one turning the clamp bolt.
- c) Move the impeller closer to the upper cutter by rotating each of the adjustment sleeves one flat clockwise, and then tightening the clamp bolts onto the adjustment sleeves. It is important to turn each adjustment sleeve exactly the same amount to keep everything parallel. Turn

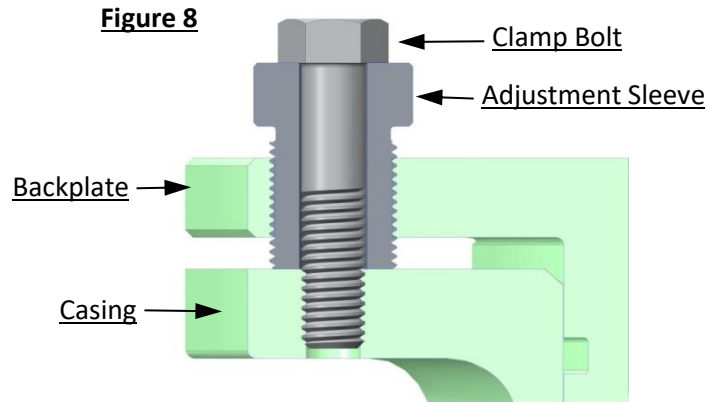

the motor coupling by hand to check for interference between the impeller and the upper cutter. Repeat this step until you feel interference. Once interference is felt, move the impeller away from the upper cutter--loosen the clamp bolts, rotate the adjustment sleeves one flat *counter clockwise*, retighten the clamp bolts--until the shaft turns freely with no contact.

Impeller-Cutter Bar Adjustment

Once the upper cutter adjustment is complete, the cutter gap on the front of the impeller can be adjusted. The clearance can be adjusted externally by modifying the position of the rotating assembly. To make this adjustment you will be moving the entire rotating assembly, including the impeller, backplate, bearing housing and motor in or out of the casing.

Once the upper cutter adjustment is complete, the cutter gap on the front of the impeller can be adjusted. The clearance can be adjusted externally by modifying the position of the rotating assembly. To make this adjustment you will be moving the entire rotating assembly, including the impeller, backplate, bearing housing and motor in or out of the casing.

- a) Remove a motor stool cover to gain access to the motor coupling. This will allow you to rotate the pump shaft by hand to check for contact between the impeller and cutting surfaces. Roll the shaft over by hand and observe how it feels before you have made any adjustments.
- b) Loosen the bolts holding the bearing housing to the baseplate. The motor feet are not bolted to the baseplate. *Don't change the motor feet adjustment!*
- c) Loosen and back off each of the clamp bolts on the casing backplate, ensuring that the adjusting sleeves do not move with the bolts. Choose three approximately equally spaced sleeves that you will use to perform the adjustments. Back all the other adjusting sleeves away from the casing by turning them counter clockwise.
- d) Before dialing in the impeller-to-cutter bar clearance, it's important to verify that the impeller and cutter bar are parallel to each other. You can check this by using a piece of key stock that is larger than the gap currently present between the backplate and casing flanges. This will generally be somewhere around $\frac{3}{16}$ " to $\frac{1}{4}$ ". Use the key stock to ensure that the gap is exactly equal at each of your three chosen adjustment sleeves with the clamp bolts tight. Before you begin to make adjustments, witness mark the three adjustment sleeves to help you confirm all of the sleeves have been rotated evenly, and the impeller and cutter bar stay parallel to each other.

- e) Decrease the impeller-to-cutter bar gap by rotating each of the three adjustment sleeves counter clockwise by an equal amount, tightening the clamp bolts, and then checking for contact by rotating the shaft. You may need to repeat this step a couple of times if the pump has some wear on it. Each flat of rotation of the adjustment sleeve hex nut is worth .010" to .012" of cutter movement. Close up the gap until light contact occurs between impeller and cutter bar.
- f) When you have the cutters lightly touching, unclamp the adjustment sleeves once again, carefully rotate them two flats clockwise, and retighten the clamp bolts. This will yield an impeller-to-cutter bar clearance of about .020" to .024". This is an acceptable number for all models of Vaughan HE series chopper pumps, 3 inch through 16 inch.
- g) Snug the unused adjustment sleeves against the casing. Make sure that the adjustment sleeves bottom on the casing, and are not tightening on anything that will crush when the clamp bolts are tightened. Lock all the adjusters down with the clamping bolts, and tighten the bolts that you loosened on the baseplate. After all bolts have been securely tightened, check for smooth shaft rotation by rotating the pump shaft again by hand. If the proper clearance cannot be achieved, or if other damage requires it, the impeller and cutter bar may need to be replaced. If this becomes necessary, refer to the overhaul manual for the proper procedures for this operation.

CAUTION

Pressure may build up in the mechanical seals used in Vaughan pumps. Whenever checking or maintaining the oil in the Vaughan cartridge seal, or the welded metal bellows seal with seal oil chamber, make sure the pumps and seal are cool to the touch. Use care when removing the oil chamber plugs, in case any residual pressure exists. If pressure exists, the plug could become a projectile and/or contaminated oil could spray.

2. Change oil in Vaughan cartridge seal as described below.

Drain Oil: Remove guard. Remove the pressure relief valve on top and the plug on the bottom to drain oil. Put a small container below the seal to collect oil. Plug the bottom hole after draining.

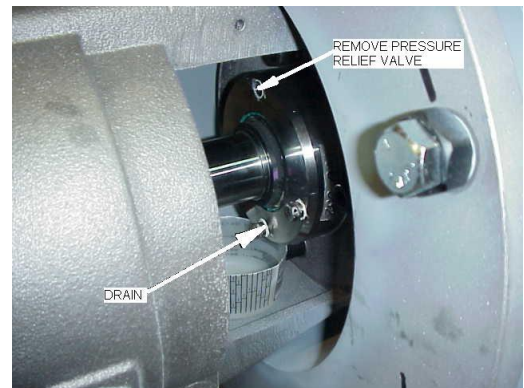

Remove plug on the side. Using a syringe and tubing fill with ISO 46 hydraulic oil until oil flows out of the hole on the side. This amounts to about 2 oz. for 3"-6" pumps and 6 oz. for 8"-16" pumps. After filling install the pressure relief valve in the top hole, with the relief port on its side, and plug the side hole. Reinstall guard.

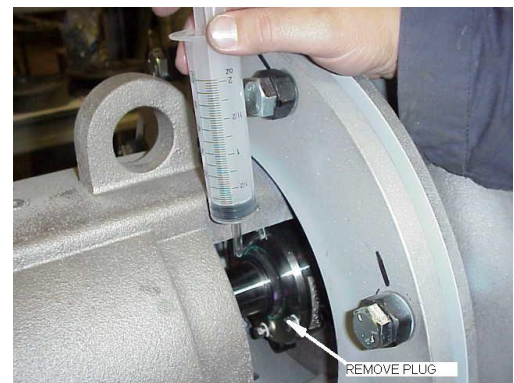

HE PUMPS ADJUSTMENT

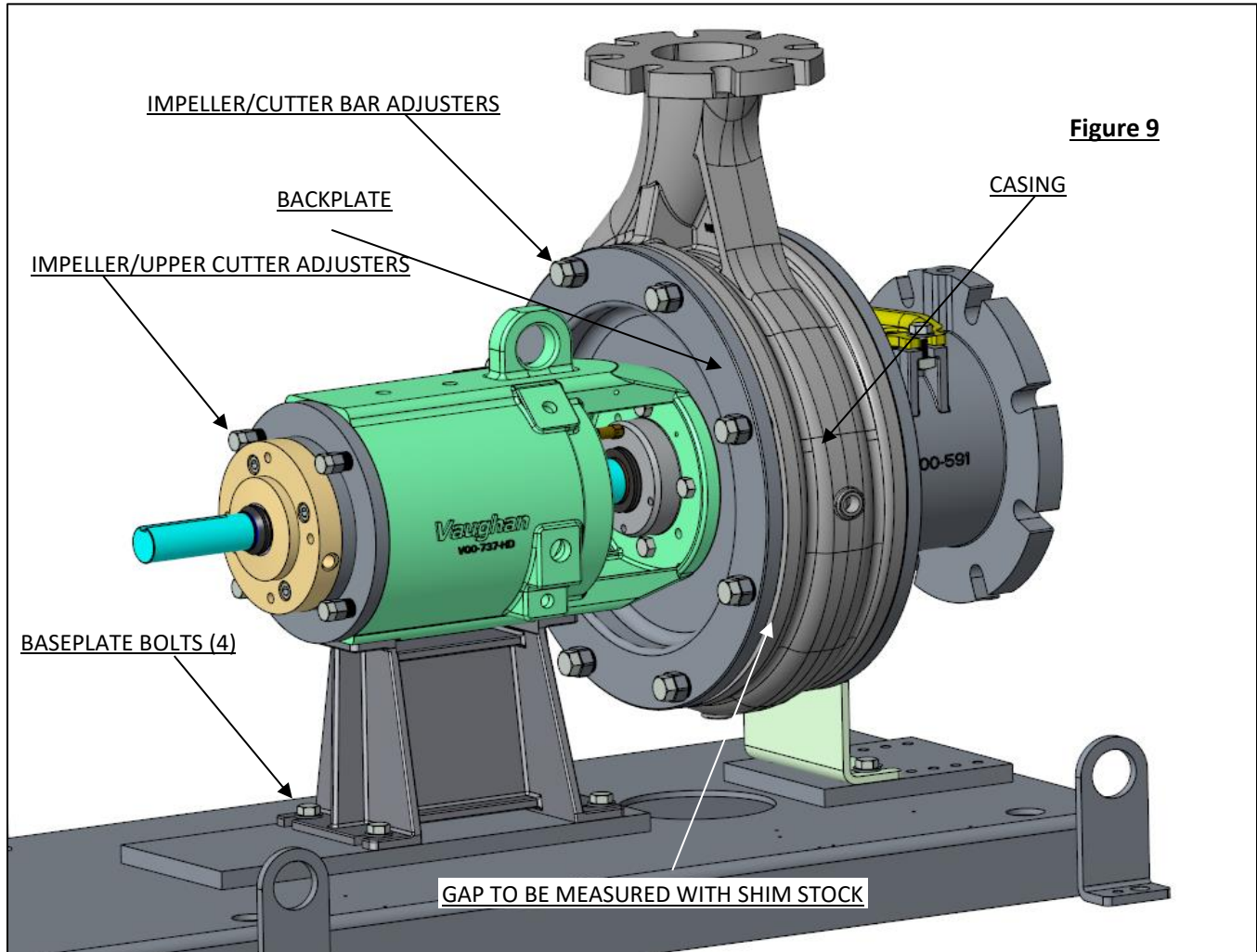

CORRECTIVE MAINTENANCE

The Overhaul Instructions for Vaughan Chopper Pumps are listed in separate manuals. Please do not try to overhaul or repair the pump without the overhaul instructions and exploded parts assembly breakdown. The overhaul instructions were sent with your pump from the factory, but if you do not have a copy of them, please contact Vaughan Co. Engineering with your pump model and serial numbers and we will make sure you get proper instructions by overnight delivery, email, or by FAX. A repair video is also available. Vaughan Company's contact information is located on the front cover of this manual.

SECTION 8: TROUBLESHOOTING

The Vaughan Horizontal End-Suction Chopper pump is more susceptible to system problems than Vaughan Wet-Well or Submersible pumps because piping is attached to the pump suction. Piping problems can cause "starving" of the pump before material has a chance to get into the pump. While Vaughan's End-Suction design has obvious advantages over other types of horizontal pumps, problems still can occur.

The following page has a troubleshooting chart that will help you get some idea of what problems could be causing your symptoms. If you would like troubleshooting help, please call Vaughan Co. for assistance.

		Low Discharge Pressure	Loss of Prime	Excessive Power Required	Excessive Stuffing Box Leakage	Short Packing or Seal Life	Abnormally High Vibration	Short Bering Life	Pump Casing Overheating	High Bearing Temperature	Low Flow
SYSTEM PROBLEMS	Pump Speed too High		✓	✓		✓	✓	✓			
	Pump Speed too Low	✓					✓				✓
	Pump Rotation Incorrect	✓	✓	✓		✓	✓				✓
	System Head too High					✓	✓	✓	✓		✓
	System Head Too Low	✓	✓	✓		✓	✓	✓			
	Specific Gravity Higher Than Expected			✓							
	Viscosity Higher Than Expected	✓		✓							✓
	Operation at Low Capacity					✓	✓	✓	✓		
	Improper Parallel Operation	✓				✓	✓		✓		✓
	Improper Series Operation						✓				
SUCTION PROBLEMS	Air Pockets in Suction Line	✓	✓				✓				✓
	Pump not Primed	✓	✓								✓
	Insufficient NPSH	✓	✓			✓	✓	✓			✓
	Suction Line Air Leaks		✓				✓				✓
	Packing Air Leaks		✓								✓
	Vortexing in Pit at Inlet	✓	✓			✓	✓				✓
	Intake opening blocked	✓	✓			✓	✓		✓		✓
MECHANICAL PROBLEMS	Pump Discharge Blocked					✓	✓	✓	✓	✓	✓
	Foundation Not Rigid					✓	✓	✓			
	Motor Adjusters not snug to base.						✓				
	Damaged Bearings			✓	✓	✓	✓			✓	
	Bent Shaft				✓	✓	✓	✓			
	Rotating Member Contacts Stationary			✓		✓	✓	✓	✓		
	Cutter Bar or Impeller Worn	✓	✓	✓			✓				✓
	Impeller Damaged	✓	✓	✓		✓	✓				✓
	Gas in pumped fluid	✓	✓		✓	✓	✓	✓			✓
	Loss of Fresh Water to Stuffing Box	✓	✓		✓	✓			✓		✓
	Loss of Bearing Lubrication			✓			✓	✓		✓	
	Improper Repair/Installation of Bearings			✓		✓	✓	✓		✓	
	Contaminated Bearings					✓	✓	✓		✓	
	Shaft Sleeve Worn	✓	✓	✓	✓	✓	✓				✓
	Packing Improperly Installed		✓			✓					
	Packing Gland Too Tight			✓		✓			✓		
	Improper Seal Elastomers for Application		✓		✓	✓					
	Seal Improperly Installed				✓	✓					
Overfill of Bearing Housing							✓		✓		

VAUGHAN CO., INC. PRODUCT WARRANTY

Vaughan Company, Inc. (Vaughan Co.) warrants to the original purchaser/end user (Purchaser) all pumps and pump parts manufactured by Vaughan Co. to be free from defects in workmanship or material for a period of one (1) year from date of startup or eighteen (18) months from the date of shipment from Vaughan Co., whichever occurs sooner. Startup data must be submitted to Vaughan Co. within 30 days of startup. If Purchaser fails to submit startup data within 30 days of startup, then Vaughan, in its sole discretion, may elect to void this warranty at any time. Purchaser must contact Vaughan Co. prior to commencing any repair attempts, or removing pump or parts from service. If Purchaser fails to contact Vaughan Co. prior to commencing any repair attempts or removing pumps or parts from service, then Vaughan, in its sole discretion, may elect to void this warranty at any time.

If during said warranty period, any pump or pump parts manufactured by Vaughan Co. prove to be defective in workmanship or material under normal use and service, and if such pump or pump parts are returned to Vaughan Co.'s factory at Montesano, WA, or to a Vaughan authorized Service Facility, as directed by Vaughan Co., transportation charges prepaid, and if the pump or pump parts are found to be defective in workmanship or material, they will be replaced or repaired by Vaughan Co. free of charge. Products repaired or replaced from the Vaughan Co. factory or a Vaughan authorized Service Facility under this warranty will be returned freight prepaid. Vaughan Co. shall not be responsible for the cost of pump or part removal and/or re-installation.

All warranty claims must be submitted in writing to Vaughan Co. not later than thirty (30) days after warranty breach occurrence. The original warranty length shall not be extended with respect to pumps or parts repaired or replaced by Vaughan Co. under this Warranty. This Warranty is voided as to pumps or parts repaired/replaced by other than Vaughan Co. or its duly authorized representatives.

Vaughan Co. shall not be liable for consequential damages of any kind, including, but not limited to, claims for property damage, personal injury, attorneys' fees, lost profits, loss of use, liability of Purchaser to customers, loss of goodwill, interest on money withheld by customers, damages related to third party claims, travel expenses, rented equipment, third party contractor's fees, or unauthorized repair service or parts. The Purchaser, by acceptance of delivery, assumes all liability for the consequences of the use or misuse of Vaughan Co. products by the Purchaser, its employees or others.

Equipment and accessories purchased by Vaughan Co. from outside sources which are incorporated into any Vaughan pump or any pump part are warranted only to the extent of and by the original manufacturer's warranty or guarantee, if any, which warranty, if appropriate, will be assigned by Vaughan Co. to the Purchaser. It is Purchaser's responsibility to consult the applicable product documentation for specific warranty information. Specific product documentation is available upon request. Any warranty shall be void if the total contract amount is not paid in full.

Vaughan Co. neither assumes, nor authorizes any person or company to assume for it, any other obligation in connection with the sale of its equipment with the exception of a valid Vaughan "Performance Guarantee" or "Extended Warranty," if applicable. Any other enlargement or modification of this warranty by a representative or other selling agent shall not be legally binding on Vaughan Co.

Warranty eligibility determination is at Vaughan Co.'s sole discretion.

Warranty Limitations:

This warranty shall not apply to any pump or pump part which has been subjected to or been damaged by any of the following non-exclusive list of causes:

- Misuse
- Abuse
- Accident
- Negligence
- Operated in the dashed portion of the published pump curves
- Used in a manner contrary to Vaughan's printed instructions
- Defective power supply
- Improper electrical protection
- Faulty installation, maintenance, or repair
- Wear caused by pumping abrasive or corrosive fluids or by cavitation
- Dissatisfaction due to buyer's remorse
- Damages incurred during transportation
- Damages incurred during installation or maintenance

THIS IS VAUGHAN CO.'S SOLE WARRANTY AND IS IN LIEU OF ALL OTHER WARRANTIES, EXPRESSED OR IMPLIED, WHICH ARE HEREBY EXCLUDED INCLUDING IN PARTICULAR ALL WARRANTIES OF MERCHANTABILITY OR FITNESS FOR A PARTICULAR PURPOSE.

