



# 12" - 16" SE-SERIES SUBMERSIBLE CHOPPER PUMPS

## Materials of Construction:

Casing/Back Pull-Out Plate/Guide Bracket/Elbow: ..... Ductile cast iron  
 Impeller/Upper Cutter/External Cutter: ..... Cast alloy steel, heat treated to minimum Rockwell C 60  
 Cutter Bar/Back Wear Plate: ..... Alloy steel, heat treated to minimum Rockwell C 60  
 Mechanical Seal: ..... Stainless steel, with silicon carbide or tungsten carbide faces  
 Discharge Flange: ..... ANSI Class 125  
 Paint: ..... Epoxy

DRAWINGS AND DIMENSIONS SUBJECT TO CHANGE WITHOUT NOTICE. DO NOT USE FOR CONSTRUCTION PURPOSES. CONTACT VAUGHAN FOR CERTIFIED CONSTRUCTION PRINTS

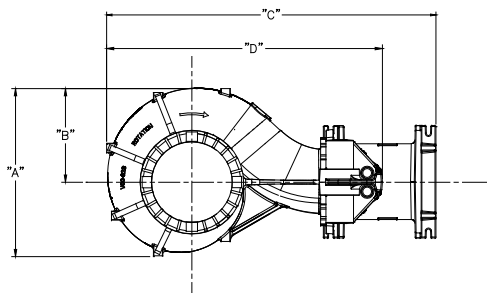

	A	B	C	D	E	F	G	H
SE12W	37-5/8	21-7/8	65	58-1/8	10-3/4	12	7-1/4	23-1/2
SE16W	44-3/4	25	87-7/8	73-1/2	17-1/4	20	6	30-1/8

DIMENSIONS IN INCHES

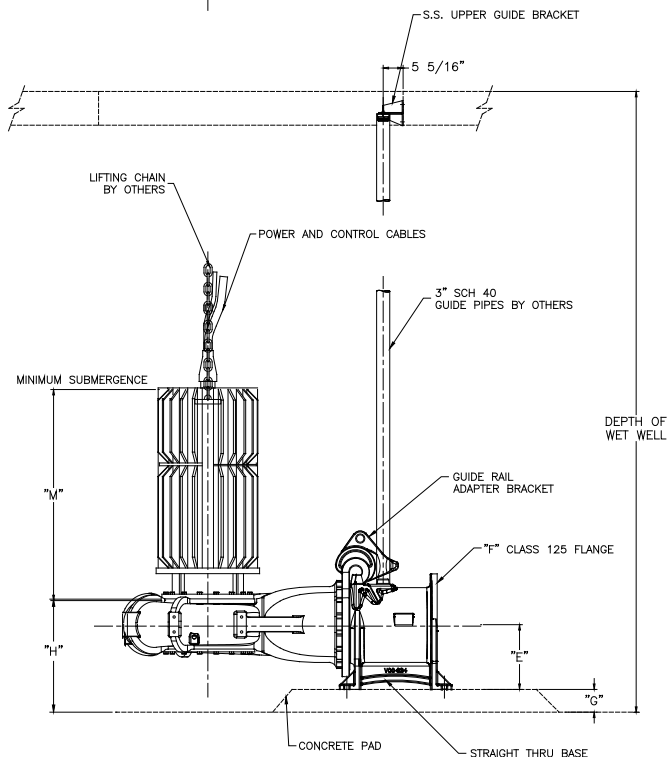

HP	SPEED	FRAME SIZE	M
75	870	360TY	32-3/8
100	870		
125	870		
150	870	445TY	52-1/2
200	870		
250	870	449TY	61

15 MINUTE IN AIR FRAME SIZES ONLY



**VAUGHAN CO., INC.**  
 364 Monte Elma Road, Montesano, WA 98563  
 Phone: 1-360-249-4042 / Fax: 1-360-249-6155  
 Toll Free Phone (US only): 1-888-249-CHOP (2467)  
 Web Site: [www.chopperpumps.com](http://www.chopperpumps.com)  
 Company E-mail: [info@chopperpumps.com](mailto:info@chopperpumps.com)

**MADE IN THE  
USA**

For all current patents, see <http://www.chopperpumps.com/patents.htm>

## SPECIFICATIONS – SE SERIES 12”-16” SUBMERSIBLE CHOPPER PUMPS

The submersible chopper pump shall be specifically designed to pump waste solids at heavy consistencies without plugging or dewatering of the solids. Materials shall be chopped/macerated and conditioned by the pump as an integral part of the pumping action. The pump must have demonstrated the ability to chop through and pump high concentrations of solids such as plastics, heavy rags, grease and hair balls, wood, paper products and stringy materials without plugging, both in tests and field applications. Pump shall be manufactured by Vaughan Co., Inc.

### DETAILS OF CONSTRUCTION

- A. Casing, Back Pull-Out Adapter Plate and Wear Plate:** The pump casing shall be of volute design, spiraling outward to the Class 125 flanged centerline discharge. Back pull-out adapter plate shall allow external adjustment of impeller-to-cutter bar clearance. Casing and adapter plate shall be ductile cast iron with all water passages to be smooth, and free of blowholes and imperfections for good flow characteristics. Backplate will include a replaceable Rockwell C 60 steel wear plate adjustable for 0.030-0.050" clearance to cut against the rotating impeller pumpout vanes for removing fiber and debris.
- B. Impeller:** Shall be semi-open type with pump out vanes to reduce seal area pressure. Chopping/maceration of materials shall be accomplished by the action of the cupped and sharpened leading edges of the impeller blades moving across the cutter bar at the intake openings, with a set clearance between the impeller and cutter bar of 0.015" - 0.025". Impeller shall be cast alloy steel, heat treated to minimum Rockwell C 60 and dynamically balanced. The impeller shall be keyed to the shaft and shall have no axial adjustments and no set screws.
- C. Cutter Bar Plate:** Shall be recessed into the pump bowl and contain at least 2 shear bars extending diametrically across the intake opening to within 0.040" - 0.060" of the rotating external cutter tooth, for the purpose of preventing intake opening blockage and wrapping of debris at the shaft area. Chopper pumps utilizing individually mounted shear bars, and which do not have a rotating external cutter extending through to the opposite side of the shear bar, shall not be acceptable. Cutter bar shall be alloy steel heat-treated to minimum Rockwell C 60.
- D. Upper Cutter:** Shall be threaded into the wear plate behind the impeller, designed to cut against the pump-out vanes and the impeller hub, reducing and removing stringy materials from the mechanical seal area. Upper cutter shall be cast alloy steel, heat treated to minimum Rockwell C 60. The upper cutter teeth are positioned as closely as possible to the center of shaft rotation to minimize cutting torque and nuisance motor tripping. The ratio of upper cutter cutting diameter to shaft diameter in the upper cutter area of the pump shall be 3.6 or less.
- E. External Cutter:** The external cutter shall be used to eliminate binding or build-up of stringy materials at the pump inlet. The external cutter shall consist of opposing cutter wings which shear against the outside surface of the shear bars and the anvil, an integral cast tooth which shears against the adjacent surface of the shear bars, and a hex head sufficiently sized for ease of removal. The external cutter shall be cast alloy steel and heat treated to a minimum Rockwell C 60.
- F. Submersible Electric Motor:** The submersible motor shall be U/L or FM listed and suitable for Class I, Group C & D, Division I hazardous locations, rated at \_\_\_ HP, \_\_\_ RPM, \_\_\_ Volts, 50 or 60 Hertz and 3 phase, 1.15 service factor (1.0 for Continuous In-Air) with Class F insulation. Motor shall be equipped with tandem independently mounted mechanical seals in oil bath and with dual moisture sensing probes. Moisture probes must be connected to indicate water intrusion. The inner and outer seals shall be separated by an oil-filled chamber. The oil chamber shall act as a barrier to trap moisture and provide sufficient time for a planned shutdown. The oil shall also provide lubrication to the internal seal. The inner seal shall be a standard John Crane Type 21 or equal, with carbon rotating faces and ceramic stationary faces. The outer seal construction shall be designed for easy replacement. Outer mechanical seal shall be 316 stainless steel metal bellows type with tungsten carbide faces. Seal shall be positively driven by set screws. Elastomers shall be of Viton®. Motor shall include two normally closed automatic resetting thermostats connected in series and imbedded in adjoining phases. The thermostats must be connected per local, state, and/or the National Electric Code to maintain hazardous location rating and to disable motor starter if overheating occurs. Motor frame shall be cast iron, and all external hardware and shaft shall be stainless steel. Motor shall be sized for non-overloading conditions.
- G. Stainless Steel Nameplate:** The stainless steel nameplate giving the manufacturer's model and serial number, rated capacity, head, speed and all pertinent data shall be mounted to a larger stainless steel plaque. Warning tags will be mounted to this same plaque. Plaque is to be fastened to wall or structure adjacent to pump.
- H. Guide Rail System:** Provide a guide rail system consisting of two galvanized or stainless steel guide rails (by others), cast ductile iron pump guide bracket and discharge elbow with mounting feet and Class 125 flanges, an upper guide rail mounting bracket and intermediate guide rail stiffener brackets every 10 feet.
- I. Optional Spark Proof Guide Rail System:** Provide a non-sparking guide rail system consisting of two galvanized or stainless steel guide rails (by others), cast aluminum bronze pump guide bracket, cast ductile iron discharge elbow with mounting feet and Class 125 flanges, upper guide rail mounting bracket, and intermediate guide rail stiffener brackets every 10 feet. System design shall prevent spark ignition of explosive gases during pump installation and removal.
- J. Surface Preparation:** Solvent wash and a single coat of Tnemec 431 epoxy (except motor).
- K. OPTIONAL Premium Surface Preparation:** Solvent wash, sandblast, and coat with minimum 30 MDFT Tnemec Perma-Shield PL Series 431 epoxy (except motor).