



12"-16" PE-SERIES VERTICAL DRY PIT CHOPPER PUMPS

Materials of Construction:

Casing/Back Pull-Out Plate:Ductile cast iron.
Impeller/Upper Cutter/External Cutter:.....Cast alloy steel heat treated to minimum Rockwell C 60.
Cutter Bar/Back Wear Plate:.....Plate steel, heat treated to minimum Rockwell C 60.
Flushless Mechanical Seal:.....Cartridge type with silicon carbide (or tungsten carbide) faces and stainless steel sleeve. (See following page for other sealing options.)
Thrust Bearings:.....Back-to-back angular contact ball type.
Radial Bearings:.....Spherical roller type.
Shaft:.....Heat treated alloy steel.
Lubrication:ISO Grade 46 oil
Flanges:ANSI Class 125 Discharge, ANSI Class 150 Suction
Mounting Base:Carbon Steel.
Paint:Epoxy.

DRAWINGS AND DIMENSIONS SUBJECT TO CHANGE WITHOUT NOTICE. DO NOT USE FOR CONSTRUCTION PURPOSES. CONTACT VAUGHAN FOR CERTIFIED CONSTRUCTION PRINTS.

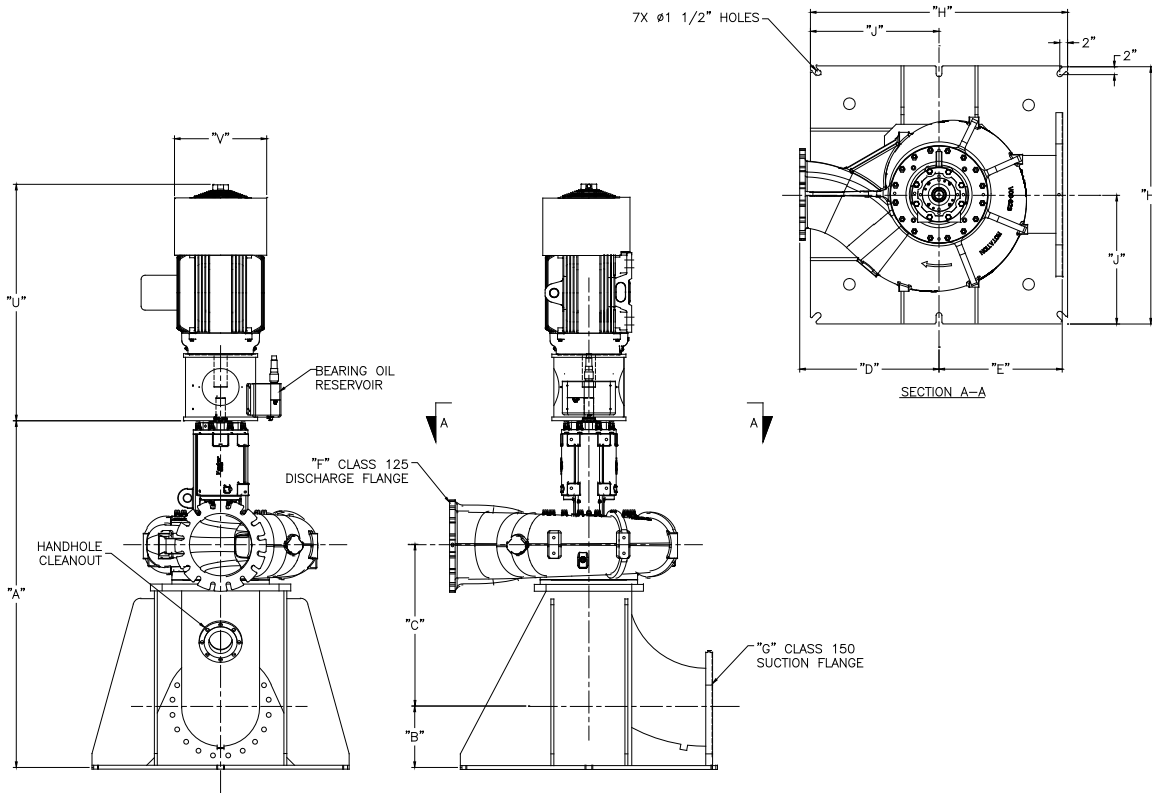

MODEL	A	B	C	D	E	F	G	H	J
PE12W18	82-3/4	15	36-1/4	27	28-5/8	12	18	60	30
PE16W20	89	15-3/4	41-1/2	35-3/4	31-5/8	16	20	66	33

MOTOR FRAME SIZE	*U	*V
404TC/405TC	47	22
444TC/445TC	54	25
447TC	58	24
449TC	66	24

*FOR REFERENCE ONLY. DIMENSIONS WILL VARY SLIGHTLY BY MOTOR MANUFACTURER



VAUGHAN CO., INC.
 364 Monte Elma Road, Montesano, WA 98563
 Phone: 1-360-249-4042 / Fax: 1-360-249-6155
 Toll Free Phone (US only): 1-888-249-CHOP (2467)
 Web Site: www.chopperpumps.com
 Company E-mail: info@chopperpumps.com

**MADE IN THE
USA**

For all current patents, see <http://www.chopperpumps.com/patents.htm>

SPECIFICATIONS – 12”– 16” PE–SERIES VERTICAL DRY PIT CHOPPER PUMPS

The vertical dry pit chopper pump shall be specifically designed to pump waste solids at heavy consistencies without plugging or dewatering of the solids. Materials shall be chopped/macerated and conditioned by the pump as an integral part of the pumping action. The pump must have demonstrated the ability to chop through and pump high concentrations of solids such as plastics, heavy rags, grease and hair balls, wood, paper products and stringy materials without plugging, both in tests and field applications. Pump shall be manufactured by Vaughan Co., Inc.

DETAILS OF CONSTRUCTION

- A. **Casing, Backplate and Wear Plate:** The pump casing shall be of volute design, spiraling outward to the Class 125 flanged centerline discharge. A ½"-NPT pressure tap shall be included on or near the discharge flange. Back pull-out plate shall allow for removal of pump components from outboard of the casing, and allow external adjustment of impeller-to-cutter bar clearance. Casing and backplate shall be ductile cast iron with all water passages to be smooth, and free of blowholes and imperfections for good flow characteristics. The wear plate shall be alloy steel heat treated to minimum Rockwell C 60 and adjustable for 0.030 – 0.050" clearance to cut against the rotating impeller pumpout vanes for removing fiber and debris.
- B. **Impeller:** Shall be semi-open type with pump out vanes to reduce seal area pressure. Chopping/maceration of materials shall be accomplished by the action of the cupped and sharpened leading edges of the impeller blades moving across the cutter bar at the intake openings, with a set clearance between the impeller and cutter bar of 0.015" - 0.025". Impeller shall be cast alloy steel, heat treated to minimum Rockwell C 60 and dynamically balanced. The impeller shall be threaded to the shaft and shall have no axial adjustments and no set screws.
- C. **Cutter Bar Plate:** Shall be recessed into the pump bowl and shall contain at least 2 shear bars extending diametrically across the intake opening to within 0.040"-0.060" of the rotating external cutter tooth, for the purpose of preventing intake opening blockage and wrapping of debris at the shaft area. Chopper pumps utilizing individually mounted shear bars, and which do not have a rotating external cutter extending through to the opposite side of the shear bar, shall not be acceptable. Cutter bar shall be alloy steel heat-treated to minimum Rockwell C 60.
- D. **Upper Cutter:** Shall be bolted into the back pull-out adapter plate behind the impeller, designed to cut against the pump-out vanes and the impeller hub, reducing and removing stringy materials from the mechanical seal area. Upper cutter shall be cast alloy steel, heat treated to minimum Rockwell C 60. The upper cutter teeth are positioned as closely as possible to the center of shaft rotation to minimize cutting torque and nuisance motor tripping. The ratio of upper cutter cutting diameter to shaft diameter in the upper cutter area of the pump shall be 3.6 or less.
- E. **External Cutter:** The external cutter shall be used to eliminate binding or build-up of stringy materials at the pump inlet. The external cutter shall consist of opposing cutter wings which shear against the outside surface of the shear bars and the anvil, an integral cast tooth which shears against the adjacent surface of the shear bars, and a hex head sufficiently sized for ease of removal. The external cutter shall be cast alloy steel and heat treated to a minimum Rockwell C 60.
- F. **Pump Shafting:** The pump shaft and impeller shall be supported by rolling element bearings. Shafting shall be heat treated alloy steel.
- G. **Bearings:** Shaft thrust in both directions shall be taken up by two face to face mounted tapered roller bearings, mounted in an adjustable position thrust bearing cartridge to permit upper cutter to impeller adjustment. A single spherical roller radial bearing shall also be provided. L-10 bearing life shall be minimum 100,000 hours.
- H. **Bearing Housing:** Shall be ductile cast iron, and machined with piloted bearing fits for concentricity of all components, and shall include a side-mounted oil reservoir. Viton® double lip seals riding on stainless steel shaft sleeves are to provide sealing at each end of the bearing housing.
- I. **Stuffing Box:** The stuffing box shall be ductile cast iron. The stuffing box shall be designed to accommodate the flushed mechanical seal, or packing as described below. Mechanical seal with no seal water flush and flushed tandem mechanical seal as described below do not require stuffing box.
- J. **Seal:** [NOTE TO CONSULTING ENGINEER: Please choose one of the 4 options below]:
- Mechanical Seal system *specifically designed to require no seal flush:* The mechanical seal shall be located immediately behind the impeller hub to eliminate the stuffing box and maximize the flushing available from the impeller pumpout vanes. The seal shall be cartridge-type mechanical seal with Viton O-rings and silicon carbide (or tungsten carbide) faces. This cartridge seal shall be a pre-assembled, pre-tested so that no seal settings or adjustments are required from the installer. Any springs used to push the seal faces together must be shielded from the fluid to be pumped. The cartridge shall also include a 17-4PH, heat-treated seal sleeve and a ductile iron seal gland.
 - Flushed Double Mechanical Seal: The seal shall be cartridge-type tandem mechanical seal with Viton O-rings and silicon carbide (or tungsten carbide) faces. This cartridge seal shall be a pre-assembled, pre-tested so that no seal settings or adjustments are required from the installer. Any springs used to push the seal faces together must be shielded from the fluid to be pumped. The cartridge shall also include a 17-4PH, heat-treated seal sleeve and a ductile iron (or stainless steel) seal gland. Seal requires flush to drain at 3 US gallons/hr flow rate.
 - Mechanical seal with throttle bushing and water fitting for seal water flush. The seal shaft sleeve shall be 316 SS. Mechanical seal materials shall be with silicon carbide faces. Seal shall be positively driven by set-screws. Elastomers shall be of Buna N, and stationary seal member shall be of the cup-mounted type to ensure cushioning of face material from mechanical shock. Contractor is to provide a 6-10 gal./hr. seal flush with filtered water, a rotameter, throttle valve, and solenoid operated isolation valve interlocked with an auxiliary contact of the motor starter.
 - Packing design with 5-ring packing split Teflon lantern ring and water fitting. The packing shaft sleeve shall be 316 SS with Nickel-Chrome-Boron coating. Contractor is to provide a filtered water packing flush at 10 PSI greater than pump discharge pressure. The flush water line is to be interlocked with an auxiliary contact of the motor starter so it is automatically turned on when the motor is started.
- K. **Inlet Manifold:** The pump assembly shall be mounted vertically with a Class 150 inlet flange, cleanout, 1/2" NPT suction pressure tap, drain connection and mounting base.
- L. **Shaft Coupling:** Bearing housing and motor stool design is to provide accurate, self-aligning mounting for a C-flanged electric motor. Pump and motor coupling shall be T.B. Woods Sureflex elastomeric type.
- M. **Stainless Steel Nameplate:** Shall be attached to the pump giving the manufacturer's model and serial number, rated capacity, head, speed and all pertinent data.
- N. Drive motor: Shall be _____ HP, _____ RPM, _____ volts, 3 phase, 60 hertz, 1.15 service factor, foot and C-flange mounted, TEFC enclosure. The motor shall be sized for non-overloading conditions.
- O. **Surface Preparation:** Solvent wash and a single coat of Tnemec 431 epoxy (except motor).
- P. **OPTIONAL Premium Surface Preparation:** Solvent wash, sandblast, and coat with minimum 30 MDFT Tnemec Perma-Shield PL Series 431 epoxy (except motor).